

# AVCO

*Alloy Valves and Control*

## BALL VALVES 9100 SERIES

# INSTALLATION, OPERATION & MAINTENANCE MANUAL



This manual covers the installation, operation and maintenance of all AVCO standard 9100 series ball valves as described in the current AVCO catalog. Custom made or customer modified versions of the 9100 series may use this manual as a general guide only.

### Alloy Valves and Control

#### 1 General Design

- 1.1 AVCO Ball valves have been designed and engineered to provide long lasting and trouble free service when used in accordance with the instructions and recommendations detailed in this manual.
- 1.2 The valves may be installed for flow or vacuum in either direction and may be installed in horizontal or vertical applications. Although the valves will operate with the handle or operator on the underside of the pipe it is not recommended and AVCO advises that, where possible, the valve handle be no more than 45° from top dead center when installed in a horizontal pipe run, particularly when an actuator other than a manual handle is used.

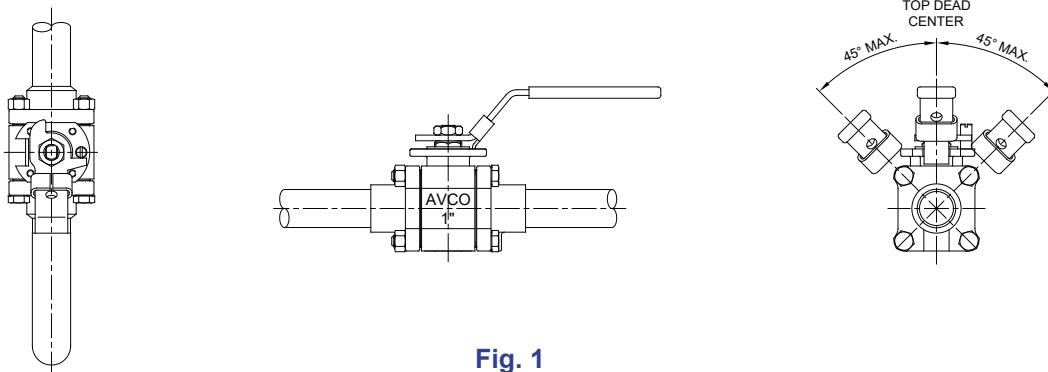

**Fig. 1**  
**Typical Valve Installations**

#### 2 Installation

- 2.1 Do not dismantle these valves when installing as they should be treated as a complete unit.
- 2.2 Ensure plastic end covers have been removed.
- 2.3 Flanged valves should be bolted and gasketed in accordance with relevant standards.
- 2.4 Connecting flanges must already be welded in place before mating with the valve.

#### 3 Operation

- 3.1 These valves provide tight shut-off when used under normal operating conditions in accordance with the relevant AVCO pressure/temperature charts.
- 3.2 If these valves are used in a partially open (throttling) condition, the seat life may be reduced as it will be exposed to flowing media in a localized area.
- 3.3 Any media which can solidify, crystallize or polymerize should not be allowed to stand in the ball valve cavities unless regular maintenance is carried out as it could lead to damage of the seats and ball thereby dramatically reducing the life.

### Alloy Valves and Control

#### 4 Manual Operation

- 4.1 All AVCO 9100 series ball valves are supplied with basic quarter turn lever handles as standard unless otherwise stated and no other lever should be used as a substitute or to create greater leverage.
- 4.2 For all valve sizes there is a lock plate for valve lock-off which is achieved by inserting a padlock or other suitable locking device through the aligned holes. The valve can only be locked open or closed, it cannot be locked in intermediate positions.
- 4.3 The handle is simply rotated provided no locking device is in place. There is a positive stop to achieve full open or full closed positions. The lever can be set to rotate clockwise to open and counter-clockwise to close or counter-clockwise to open and clockwise to close by simply removing the lever and flipping the locking plate over.
- 4.4 The handle or lever on all valve sizes gives visual indication as to whether the valve is in the open or closed position. If the handle/lever is in-line (parallel) with the pipeline, then the valve is open or if the handle/lever is perpendicular to (across) the pipeline, then the valve is closed.

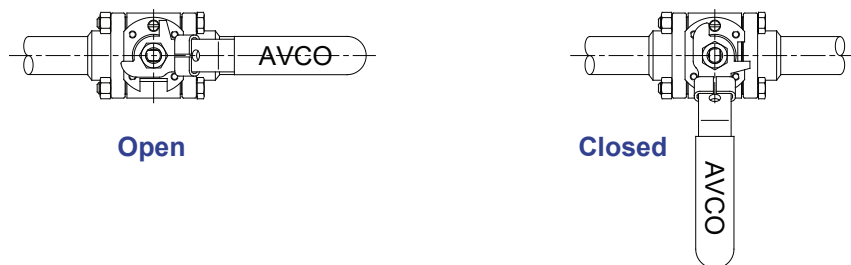

**Fig. 2**  
**Valve Open/Closed Indication**

#### 5 Automated Operation

- 5.1 These valves can be set up for automated operation as part of a process control system. AVCO supplies a large range of pneumatic and electric actuators with associated controls to accommodate most design conditions.
- 5.2 The handle/lever, and travel stop plate should be removed for automated actuation if not already specified in the purchase order.
- 5.3 The stem has milled flats which are machined to exacting tolerances to ensure positive location. The flats (1/2" thru 4") or indicator line cut into the top of the stem (6" thru 12") also indicate valve ball position. When the flats or indicator line are parallel to the pipeline, the valve is open and when the flats or indicator line are perpendicular to the pipeline, the valve is closed.
- 5.4 There is no positive stop on the valve for open and closed positions when set up for actuator usage as it is intended that the actuator will control the valve travel.

Alloy Valves and Control

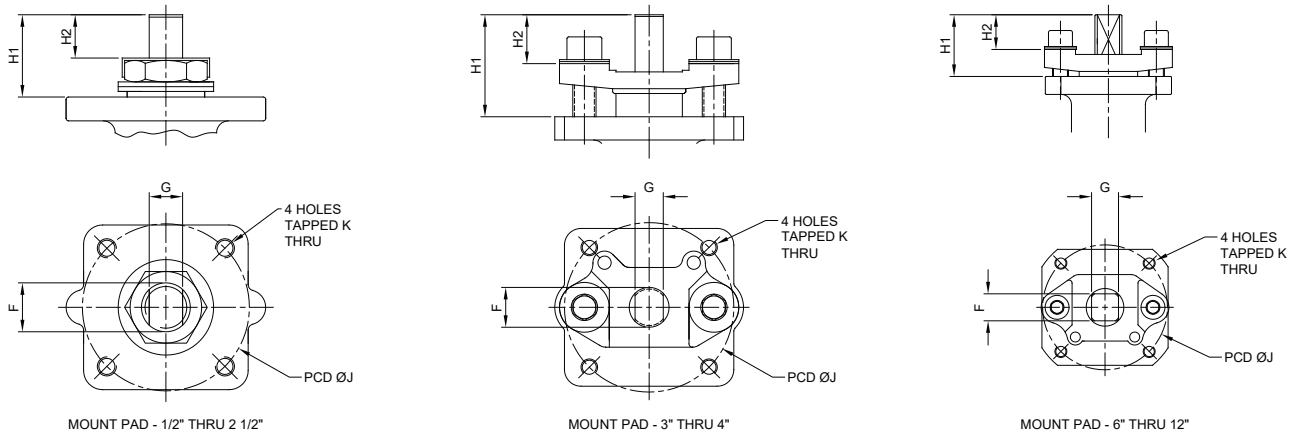

Fig. 3 - Valve Stem & Mount Pad Set-Up

SIZE	ANS Class	F (in.)	G	H1 (in.)	H2 (in.)	J (in.)	K (in.)	ISO 5211	Weight (lbs)	TORQUE (in-lbs)	CV
1/2"	150#	M10	0.297	0.69	0.39	1.654	M5	F04	4.6	84	23
	300#	M10	0.297	0.69	0.37	1.654	M5	F04	7.1	84	23
3/4"	150#	M10	0.297	0.73	0.39	1.654	M5	F04	5.3	96	53
	300#	M10	0.297	0.69	0.37	1.654	M5	F04	9.5	96	53
1"	150#	M14	0.342	1.16	0.72	1.969	M6	F05	5.7	120	94
	300#	M14	0.342	1.06	0.63	1.969	M6	F05	10.6	120	94
1 1/4"	150#	M14	0.342	1.06	0.63	1.969	M6	F05	11.5	178	118
	300#	M14	0.342	1.06	0.63	1.969	M6	F05	13.9	178	118
1 1/2"	150#	M20	0.551	1.46	0.69	2.756	M8	F07	15.0	216	213
	300#	M20	0.551	1.46	0.69	2.756	M8	F07	15.9	216	213
2"	150#	M20	0.551	1.50	0.69	2.756	M8	F07	19.8	300	378
	300#	M20	0.551	1.50	0.69	2.756	M8	F07	27.6	300	378
2 1/2"	150#	M20	0.551	1.50	0.69	2.756	M8	F07	32.0	531	660
	300#	M20	0.551	1.50	0.69	2.756	M8	F07	40.4	531	660
3"	150#	0.984	0.669	2.42	1.14	4.016	M10	F10	43.0	781	951
	300#	0.984	0.669	2.42	1.14	4.016	M10	F10	70.6	781	951
4"	150#	0.984	0.669	2.42	1.14	4.016	M10	F10	72.8	1444	1691
	300#	0.984	0.669	2.42	1.14	4.016	M10	F10	101	1444	1691
6"	150#	1.063	1.063	2.43	1.34	4.921	M12	F12	137	3356	3806
	300#	1.063	1.063	2.44	1.34	4.921	M12	F12	194	3356	3806
8"	150#	1.260	1.260	3.11	1.59	4.921	M12	F12	243	12744	7812
	300#	1.260	1.260	3.11	1.59	4.921	M12	F12	359	12744	7812
10"	150#	1.417	1.417	3.37	1.83	5.512	M16	F14	366	15930	13371
	300#	1.417	1.417	3.37	1.83	5.512	M16	F14	525	15930	13371
12"	150#	1.811	1.811	4.98	2.66	6.496	M20	F16	523	21240	19255
	300#	1.811	1.811	4.98	2.66	6.496	M20	F16	783	21240	19255

Table 1 - Valve Stem & Mount Pad Dimensions in Inches

***Alloy Valves and Control***

- 5.5 The mount pad for each valve conforms to ISO 5211 and the stem dimensions are as shown in fig. 3 and table 1 below. Standard ISO brackets and couplers are available from AVCO to suit a wide range of actuator styles.
- 5.6 AVCO advises, that where an actuator is used, the valve be installed as shown in fig. 1 and as described in paragraph 1.2 for optimal use and life span.
- 5.7 It is imperative that any bracket/coupler combination allows adequate clearance to ensure that the coupler does not exert any compressive force directly on to the stem or stem nut, as this could lead to premature stem leakage and possible damage. When assembled it should be possible for the coupler to freely move up and down by a small amount.

**6 Maintenance**

- 6.1 AVCO valves will give a long and trouble free life provided they are operated within the specified design parameters, but occasionally maintenance is required and should be addressed as set out in this section:

**6.2 Stem Leakage - 1/2" thru 2 1/2"**

- 6.2.1 Remove the handle/lever retaining nut or screw, handle/lever, travel stop (1 1/2" thru 2 1/2") and lock washer.
- 6.2.2 Examine the Belleville washers and check the outer edges are touching and concentric. If all appears to be OK, continue to 6.2.4.
- 6.2.3 Remove stem nut, replace Belleville washers (if necessary) and ensure that the outside edges are touching concentrically. Replace the stem nut.
- 6.2.4 Tighten the stem nut until the required torque is achieved (see table 2) or until the Belleville washers are flattened and then back off by the minimum amount required until the lock washer can be located onto the stem nut.
- 6.2.5 Replace the handle/lever and handle/lever nut or screw.
- 6.2.6 If stem leakage still occurs the valve will require refurbishment, full instructions are listed in section 7.

**6.3 Stem Leakage - 3" thru 12"**

- 6.3.1 If possible place valve in open position or if not remove the handle/lever retaining screw and handle/lever.
- 6.3.2 Examine the packing flange Belleville washers and check the outer edges are touching and concentric. If all appears to be OK, continue to 6.3.4.
- 6.3.3 Remove/loosen the packing gland screws, replace Belleville washers (if necessary) and ensure that the outside edges are touching concentrically. Replace the packing gland screws and hand tighten.
- 6.3.4 Tighten the packing gland screws until the required torque is achieved (see table 2) or until the Belleville washers are flattened.
- 6.3.5 Replace the handle/lever and handle/lever nut or screw if it was removed in 6.3.1.
- 6.3.6 If stem leakage still occurs the valve will require refurbishment, full instructions are listed in section 7.

## Alloy Valves and Control

### 6.4 Leakage at Body Joint

- 6.4.1 Check the body bolt torque settings and tighten to the required torque (see table 2) using the suggested bolt tightening sequence (see the bolting information section).
- 6.4.2 If leakage is still encountered the body seals will require replacement or the mating faces may be damaged and should be inspected as detailed in section 7.

### 6.5 In-Line Leakage

- 6.5.1 Check that the valve is fully closing and that there are no restrictions preventing the full rotation to the closed position.
- 6.5.2 If the full travel is being achieved then it is likely that the valve seats or ball is damaged or worn and may require replacement. See section 7 for details on how to carry out a complete refurbishment.

### 6.6 Leakage at Pipeline Joint

- 6.6.1 Ensure that mating faces and gasket are not damaged and verify that all bolts have been tightened to the relevant torque giving adequate gasket compression. Gasket compression and bolting torque for flanged joints should be specified by the gasket supplier.

## 7 Refurbishing

- 7.1 AVCO Valves can be refurbished if the need arises and complete maintenance kits are available or individual components purchased as required. A maintenance kit consists of thrust ring, thrust seal, packing, Belleville washers, seats and body seals in quantities relevant to the specified valve size.

**NOTE:** If any of the seal, seat or washer materials differ to that of the originally supplied specification, then the nameplate must be revised or the valve tagged to indicate the change as the temperature and pressure range could be affected.

**WARNING: Ball valves are designed as pressure containing equipment and as such a risk assessment must be carried out to ensure that no pressurized fluid or gas is contained in the ball cavity and relevant procedures followed for the handling of hazardous materials before any work commences.**

**NOTE:** The following instructions assume that all relevant safety checks have been carried out, the valve has been removed from the pipeline and are purely aimed at valve refurbishment.

- 7.2 Prepare a clean working area.
- 7.3 If fitted, remove any actuators and associated brackets per manufacturers' instructions.
- 7.4 With the valve in the open position, remove the body bolt nuts.
- 7.5 Separate the end cap from the main body whilst taking care not to damage the mating faces.
- 7.6 Remove the seat from the end cap.
- 7.7 Carefully rotate the ball in the main body of the valve to the closed position, remove the ball, second seat and body seal.
- 7.8 Inspect the stem assembly and if it is considered to be in good condition skip to paragraph 7.11.

### 7.9 Dismantling & reassembling stem assembly - 1/2" thru 2 1/2"

- 7.9.1 If fitted, unscrew the handle retaining nut/screw and remove the handle/lever. The travel stop (1 1/2" thru 2 1/2") and stop pin can also be removed. Please note that these items are not installed if the valve has been set up for powered actuation.

***Alloy Valves and Control***

- 7.9.2 Remove the stem nut lock washer.
- 7.9.3 Use a wrench on the stem flats to prevent the stem from turning, unscrew the stem nut and remove. The Belleville washers, gland ring, travel stop (1/2" thru 1 1/4") and packing can now be removed. The stem and thrust seal can be withdrawn via the body cavity.
- 7.9.4 Thoroughly clean all components with a suitable cleaning fluid. If there is any build-up of solids, use a blunt tool (preferably not metal) and ensure machined surfaces are not scratched. If any component shows signs of eroded or corroded leak paths or damage to machined areas, it should be replaced.
- 7.9.5 Fit the thrust seal onto the stem.
- 7.9.6 Insert the stem complete with thrust seal up into the valve body.
- 7.9.7 Ease the packing onto the stem whilst taking care not to damage it, followed by the gland ring.
- 7.9.8 Place the Belleville washers onto the stem whilst ensuring that the outside edges are touching concentrically. The travel stop (if fitted - 1/2" thru 1 1/4") can also be located onto the stem at this stage.
- 7.9.9 Replace the stem nut and Tighten the stem nut until the required torque is achieved (see table 2) or until the Belleville washers are flattened and then back off by the minimum amount required until the lock washer can be located onto the stem nut.
- 7.9.10 Operate the stem several times and re-tighten if required.
- 7.9.11 Screw in the stop pin(s), install the travel stop (1 1/2" thru 2 1/2"), replace the handle/lever and handle/lever nut or screw. Please note that these items are not fitted for powered actuation.

**7.10 Dismantling & reassembling stem assembly - 3" thru 12"**

- 7.10.1 Remove the handle retaining screw from the valve stem, remove the handle, handle washer and stem washer (6" thru 12").
- 7.10.2 Support the stem from inside the body and remove the stem retaining ring and locking plate. It should now be possible to withdraw the stem from inside the body at which point the thrust seal can be removed.
- 7.10.3 Unscrew the packing gland screws and remove Belleville washers. The packing gland flange, gland ring (3" thru 4"), bushing (6" thru 12") and packing can now be removed.
- 7.10.4 Thoroughly clean all components with a suitable cleaning fluid. If there is any build-up of solids, use a blunt tool (preferably not metal) and ensure machined surfaces are not scratched. If any component shows signs of eroded or corroded leak paths or damage to machined areas, it should be replaced.
- 7.10.5 Fit the thrust seal onto the stem.
- 7.10.6 Insert the stem complete with thrust seal up into the valve body. The stem will require supporting from inside the valve body until the stem retaining ring has been installed at a later stage.
- 7.10.7 Ease the packing onto the stem and into the body cavity, followed by the gland ring.
- 7.10.8 Insert the bushing (6" thru 12") into the gland flange and locate the gland flange onto the stem followed by the locking plate. Place Belleville washers onto the gland screws and tighten to the

### Alloy Valves and Control

required torque (see table 2) or until the Belleville washers are flattened. The Belleville washers should have their outside edges touching concentrically. The stem retainer ring can be inserted as soon as it is possible to do so.

- 7.10.9 Operate the stem several times and re-tighten the gland screws if required.
  - 7.10.10 Place the stem washer (6" thru 12") on the stem followed by the handle. For stems with square drives, it is essential the handle is assembled so that when the valve is in the open position, the handle is parallel to the pipeline. A quick check is to ensure that the handle is perpendicular to the flats on the stem which locate with the ball.
  - 7.11 Inspect the ball which must have no scratches or scoring, other than minor signs of rubbing, around its seating periphery (fig. 4). If the ball does not pass inspection it should be replaced.
  - 7.12 Place a seat in the body cavity and another in the end cap. Ensure the seats are the right way round - angled seating face should be visible.
  - 7.13 Replace the ball into the valve body (whilst in closed position) and carefully rotate to the open position.
- NOTE:** A trace of silicon based lubricant or clean grease (i.e. Petroleum jelly), if compatible with pipeline media, will assist with rebuilding by holding the seats and body seals in place. **DO NOT** use grease with abrasive additives.
- 7.14 Place the body seal onto the end cap and ease the completed end cap into the main body.
  - 7.15 Replace the body nuts onto the body studs and tighten to the required torque using the suggested bolt tightening sequence (see the bolting information section). It is suggested that periodic opening and closing be performed during the tightening sequence to help with concentricity, as it is possible for the ball to be trapped between the seats, especially in horizontal applications.
  - 7.16 If possible the valve should be tested at design pressure for any leakage and relevant corrective action taken as necessary.

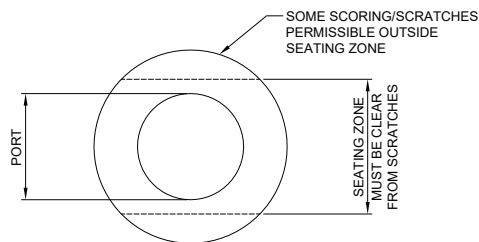

**Fig. 4**  
**Ball Inspection**



### Alloy Valves and Control

#### 8 Bolting Information

- 8.1 Stem nuts should be tightened finger tight and then torqued per table 2 or tightened with a wrench until the Belleville washers are fully flat. Once the required tightening has been achieved, the nut should be backed off no more than 1/8 turn until the lock pad can be assembled onto the stem.
- 8.2 Packing gland screws should be tightened finger tight and then torqued per table 2 or tightened with a wrench until the Belleville washers are fully flat.
- 8.3 Body stud nuts should be tightened until finger tight and then gradually fully tightened per the bolting sequence shown in paragraphs 8.4 through 8.8 to the torque shown in table 2. It is important that tightening be done gradually so as not to trap or pinch any part of the seats or seals and to maintain concentricity.

##### 8.4 Four bolt sequence.

- 8.4.1 First round to 30% torque - 1-2, 3-4
- 8.4.2 Second round to 60% torque - 1-2, 3-4
- 8.4.3 Third round to 100% torque - 1-2, 3-4
- 8.4.4 Final checking round - 1,3,2,4

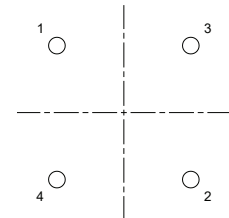

##### 8.5 Six bolt sequence

- 8.5.1 First round to 30% torque - 1-2, 3-4, 5-6
- 8.5.2 Second round to 60% torque - 1-2, 3-4, 5-6
- 8.5.3 Third round to 100% torque - 1-2, 3-4, 5-6
- 8.5.4 Final checking round - 1,6,4,2,5,3

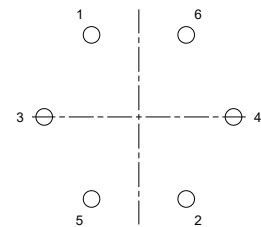

##### 8.6 Eight bolt sequence

- 8.6.1 First round to 30% torque - 1-2, 3-4, 5-6, 7-8
- 8.6.2 Second round to 60% torque - 1-2, 3-4, 5-6, 7-8
- 8.6.3 Third round to 100% torque - 1-2, 3-4, 5-6, 7-8
- 8.6.4 Final checking round - 1,5,3,7,2,6,4,8

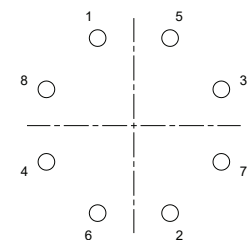

##### 8.7 Twelve bolt sequence

- 8.7.1 First round to 20% torque - 1-2, 3-4, 5-6, 7-8, 9-10, 11-12
- 8.7.2 Second round to 40% torque - 1-2, 3-4, 5-6, 7-8, 9-10, 11-12
- 8.7.3 Third round to 80% torque - 1-2, 3-4, 5-6, 7-8, 9-10, 11-12
- 8.7.4 Fourth round to 100% torque - 1-2, 3-4, 5-6, 7-8, 9-10, 11-12
- 8.7.5 Final checking round - 1,5,9,3,7,11,2,6,10,4,8,12

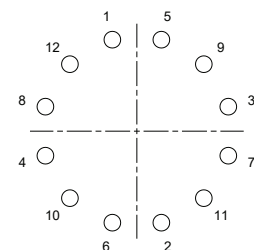

### Alloy Valves and Control

#### 8.8 Sixteen bolt sequence

- 8.8.1 1st round to 20% torque - 1-2, 3-4, 5-6, 7-8, 9-10, 11-12, 13-14, 15-16
- 8.8.2 2nd round to 40% torque - 1-2, 3-4, 5-6, 7-8, 9-10, 11-12, 13-14, 15-16
- 8.8.3 3rd round to 80% torque - 1-2, 3-4, 5-6, 7-8, 9-10, 11-12, 13-14, 15-16
- 8.8.4 4th round to 100% torque - 1-2, 3-4, 5-6, 7-8, 9-10, 11-12, 13-14, 15-16
- 8.8.5 Final checking round - 1,9,5,13,3,11,7,15,2,10,6,14,4,12,8,16

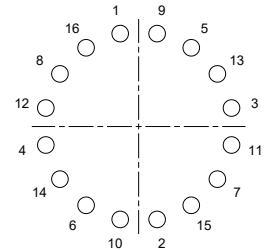

Valve Size	ANSI Class	Body Studs		Packing Gland Screws		Stem Nuts	
		Size	Torque (ft.lbs)	Size	Torque (ft.lbs)	Size	Torque (ft.lbs)
1/2"	150	M8	26	-	-	M10	20
	300	M10	38	-	-	M10	24
3/4"	150	M8	26	-	-	M10	20
	300	M10	38	-	-	M10	24
1"	150	M10	38	-	-	M14	22
	300	M12	50	-	-	M14	33
1 1/4"	150	M10	38	-	-	M14	22
	300	M12	50	-	-	M14	33
1 1/2"	150	M12	50	-	-	M20	48
	300	M16	100	-	-	M20	57
2"	150	M12	50	-	-	M20	48
	300	M12	50	-	-	M20	57
2 1/2"	150	M12	50	-	-	M20	48
	300	M12	50	-	-	M20	57
3"	150	M12	50	M14	22	-	-
	300	M14	75	M14	33	-	-
4"	150	M12	50	M14	22	-	-
	300	M16	100	M14	33	-	-
6"	150	M16	100	M16	33	-	-
	300	M20	170	M16	40	-	-
8"	150	M20	170	M16	33	-	-
	300	M24	385	M16	40	-	-
10"	150	M20	170	M20	48	-	-
	300	M24	385	M20	57	-	-
12"	150	M20	170	M20	48	-	-
	300	M24	385	M20	57	-	-

**Table 2**  
**Valve Torque Settings**

***Alloy Valves and Control***

- 8.9 If a bolt, screw, stud or nut is damaged or lost, it should be replaced with one of exactly the same specification as that originally supplied. AVCO holds spares in stock.

**9 Valve Conformance**

- 9.1 The valve shall be deemed to conform with its originally supplied specifications provided that:
- 9.1.1 The maintenance kit material is identical to that of the originally specified valve or the name-plate be revised to show the new conditions.
  - 9.1.2 Any component that is replaced during maintenance or repair is an AVCO authorized spare part and is specific to the originally specified valve. Any component of the valve can be replaced, but AVCO recommends that if the body becomes damaged then the complete valve be replaced.
  - 9.1.3 Parts from different AVCO valve series should not be inter-changed unless authorized by AVCO.
  - 9.1.4 Parts from other valve manufacturers must not be used.
  - 9.1.5 If the valve is altered in any way from that of the original specification or without consent from AVCO, then no liability can be accepted by AVCO (Alloy Valves & Control).

**10 Safety Precautions**

- 10.1 Ascertain what media the pipeline carries before removing or working on any fitted valve. The media can be corrosive, toxic, flammable or a contaminant. Where there is evidence of harmful or hazardous media ever flowing through the valve, then utmost care must be taken. As a minimum AVCO suggests the following precautions be taken, but it is the responsibility of the owner/operator to ensure that a risk assessment is carried out and relevant safety procedures followed thereof.
- 10.2 Wear eye protectors.
  - 10.3 Wear protective overalls and gloves.
  - 10.4 Wear protective headgear.
  - 10.5 Wear protective footwear.
  - 10.6 Ensure running water is easily accessible.
  - 10.7 Have a suitable fire extinguisher nearby.
  - 10.8 Check Upstream and downstream pressure gauges to ensure the pipeline contains no pressure.
  - 10.9 Ensure any pressurized media in the ball or cavity is released by opening the valve half open.
  - 10.10 Ideally the valve should be flushed or decontaminated with the valve in the half open position to clear ball and body cavity.

## 11 General Assemblies

11.1 The following figures show the typical general assemblies and materials for all valve sizes.

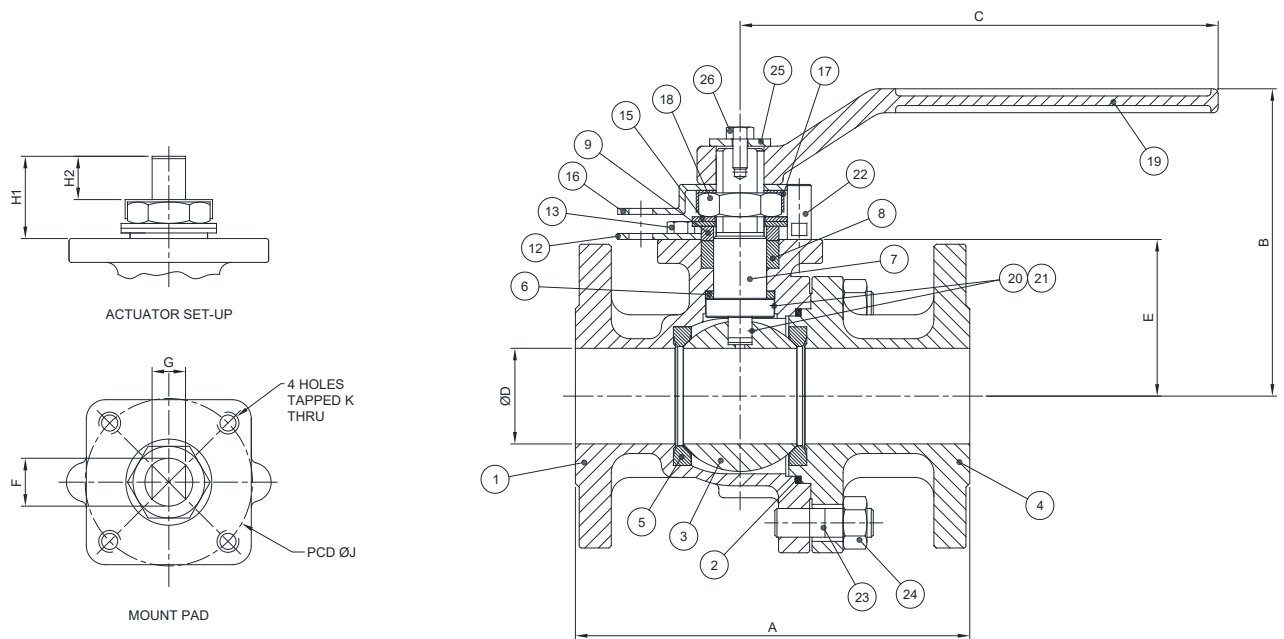
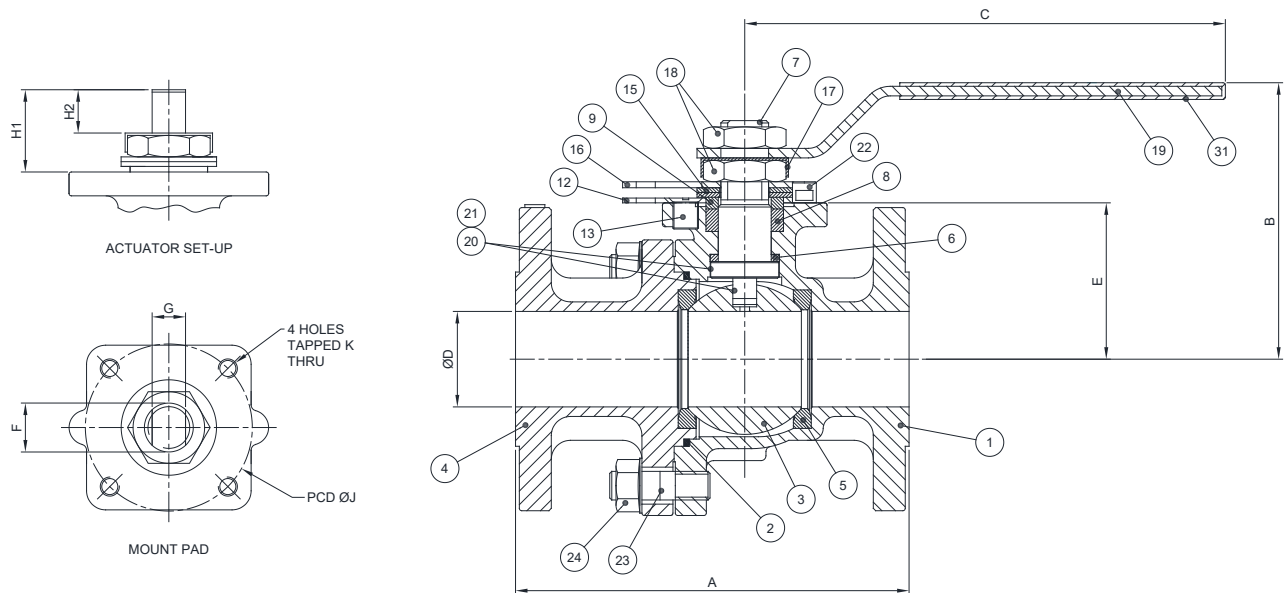

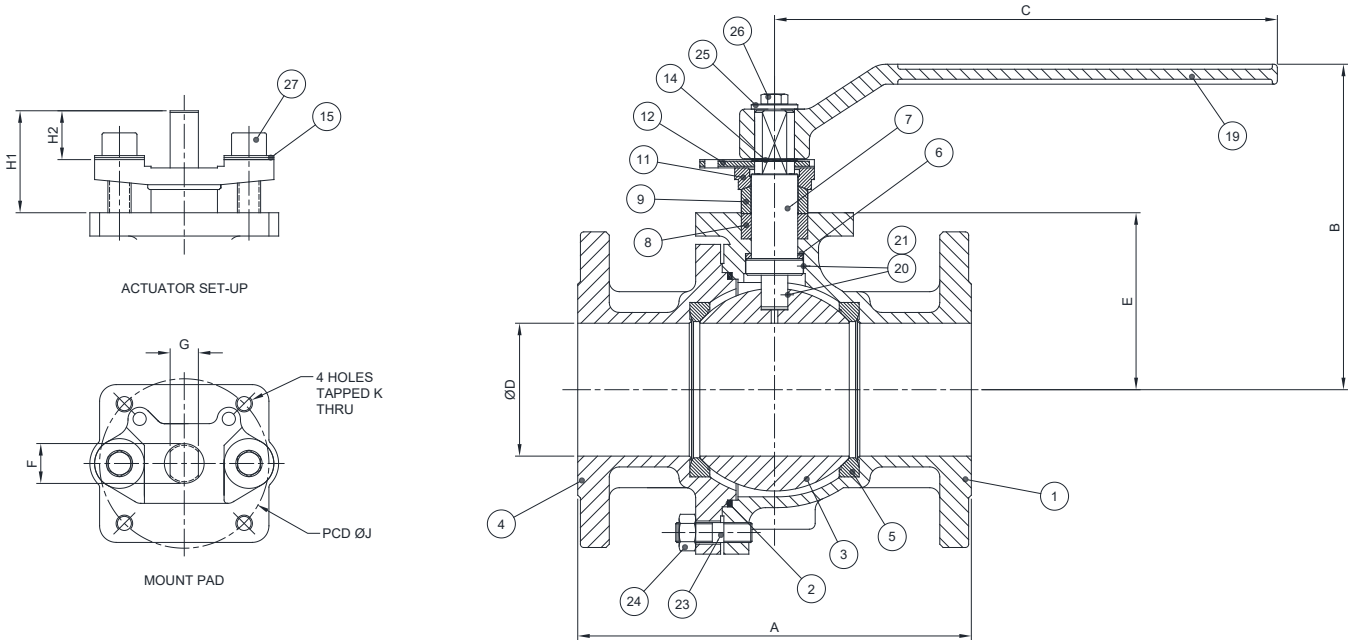

Fig. 7 - 3" thru 4"

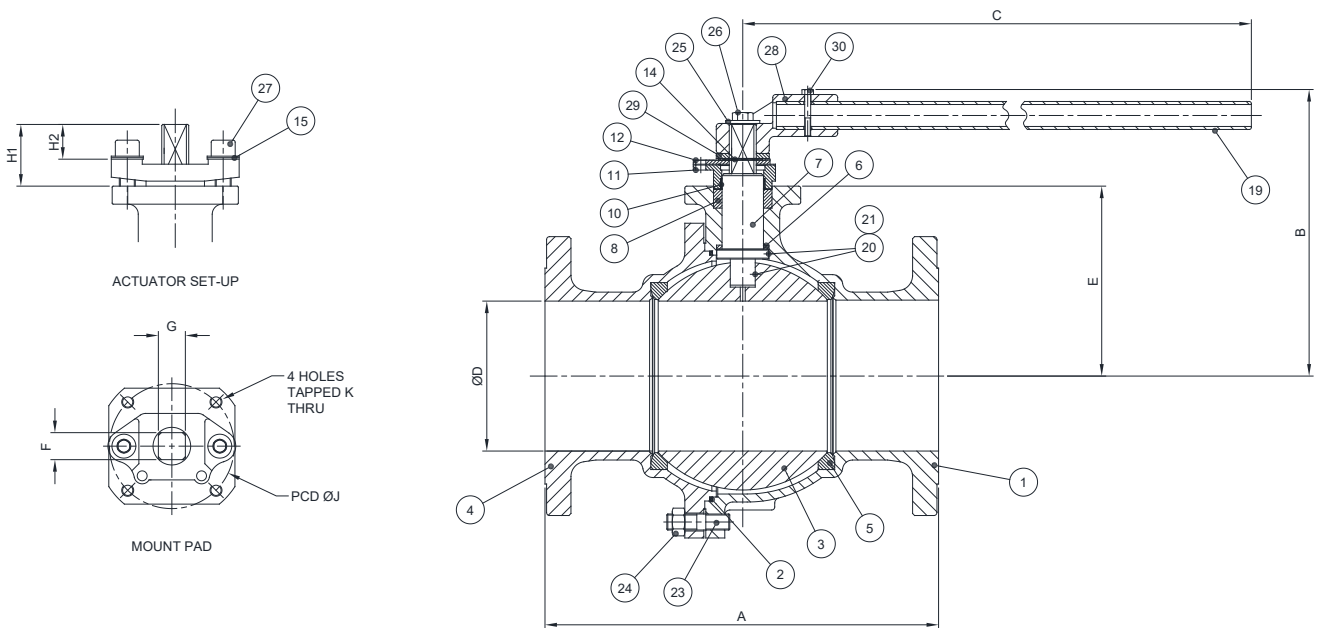

Fig. 8 - 6" thru 12"

Item	Description	Part of Valve Assembly				Material		
		1/2" thru 1 1/4"	1 1/2" thru 2 1/2"	3" thru 4"	6" thru 12"	Stainless Steel	Alloy 20	Carbon Steel
1	Body	Yes	Yes	Yes	Yes	A351-CF8M	Alloy 20	A216-WCB
2	Body Seal	Yes	Yes	Yes	Yes	SS 316/Graphite	SS 316/Graphite	SS 316/Graphite
3	Ball	Yes	Yes	Yes	Yes	A351-CF8M	Alloy 20	A351-CF8M
4	End Cap	Yes	Yes	Yes	Yes	A351-CF8M	Alloy 20	A216-WCB
5	Seat	Yes	Yes	Yes	Yes	RPTFE	RPTFE	RPTFE
6	Thrust Seal	Yes	Yes	Yes	Yes	TFM 4215	TFM 4215	TFM 4215
7	Stem	Yes	Yes	Yes	Yes	A276-316	Alloy 20	A276-316
8	Packing	Yes	Yes	Yes	Yes	Grafoil	Grafoil	Grafoil
9	Gland Ring	Yes	Yes	Yes	No	A276-316	Alloy 20	A276-316
10	Bushing	No	No	No	Yes	PTFE	PTFE	PTFE
11	Packing Gland	No	No	Yes	Yes	A351-CF8M	Alloy 20	A216-WCB
12	Locking Plate	Yes	Yes	Yes	Yes	Stainless Steel	Stainless Steel	Stainless Steel or Steel
13	Locking Plate Screw	Yes	Yes	No	No	A193-B8	A193-B8	A193-B7
14	Locking Plate Retainer	No	No	Yes	Yes	Stainless Steel	Stainless Steel	Steel
15	Belleville Washer	Yes	Yes	Yes	Yes	A276-301	A276-301	A276-301
16	Travel Stop	Yes	Yes	No	No	Stainless Steel	Stainless Steel	Stainless Steel
17	Lock Washer	Yes	Yes	No	No	Stainless Steel	Stainless Steel	Stainless Steel
18	Stem Nut	Yes	Yes	No	No	A276-304	A276-304	A276-304
19	Handle	Yes	Yes	Yes	Yes	Steel	Steel	Steel
20	Anti-Static Ball	Yes	Yes	Yes	Yes	A276-316	A276-316	A276-316
21	Spring	Yes	Yes	Yes	Yes	A276-316	A276-316	A276-316
22	Stop Pin	Yes	Yes	No	No	Stainless Steel	Stainless Steel	Stainless Steel
23	Threaded Rod	Yes	Yes	Yes	Yes	A193-B8	A193-B8	A193-B7
24	Body Nut	Yes	Yes	Yes	Yes	A194-8	A194-8	A194-2H
25	Handle Washer	No	Yes	Yes	Yes	Stainless Steel	Stainless Steel	Stainless Steel
26	Handle Screw	No	Yes	Yes	Yes	A193-B8	A193-B8	A193-B7
27	Packing Gland Screw	No	No	Yes	Yes	A193-B8	A193-B8	A193-B7
28	Handle Block	No	No	No	Yes	A216-WCB	A216-WCB	A216-WCB
29	Stem Washer	No	No	No	Yes	Stainless Steel	Stainless Steel	Stainless Steel
30	Handle Block Screw	No	No	No	Yes	A193-B8	A193-B8	A193-B7
31	Handle Sleeve	Yes	No	No	No	Plastic	Plastic	Plastic

Table 3