

AVCO

Alloy Valves and Control

TRUNNION BALL VALVES 11100 SERIES

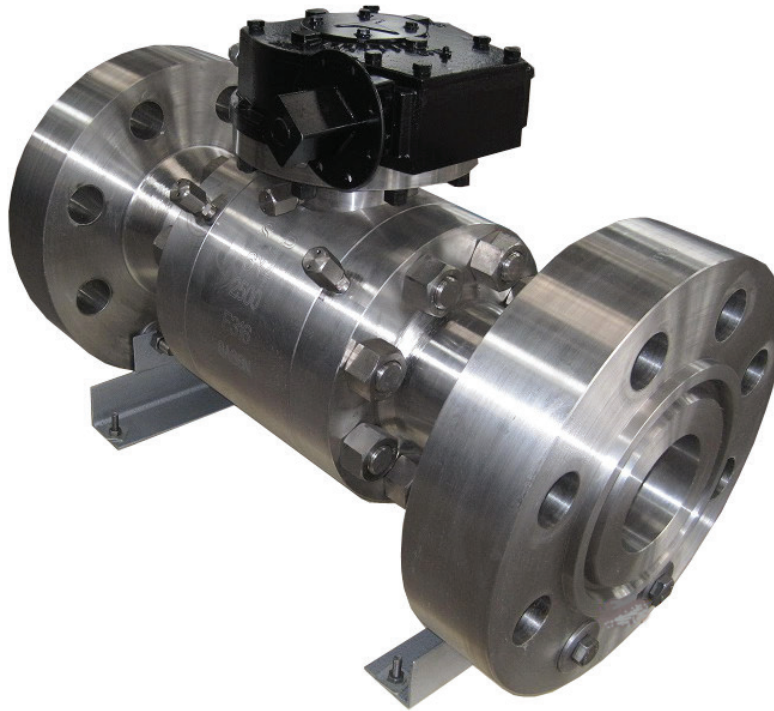

Size

2" - 28" (Full Port)
Fire Safe as Standard

End Connections

150# RF Flanged
300# RF Flanged
600# RF or RTJ Flanged
900# RF or RTJ Flanged
1500# RF or RTJ Flanged
2500# RF or RTJ Flanged
Butt Weld

Valve Materials

304/304L/316/316L Stainless Steel
Carbon Steel
Low Temp. Carbon Steel

Ball and Stem Materials

304/304L/316/316L Stainless Steel
Nickel Plated Carbon Steel

Seat Materials

Teflon
Nylon
PEEK
Devlon
Metal

Service Applications

Chemical
Food Processing
Oxygen
Refining
Steam
Thermal Fluids
Water/Oil/Gas

Applicable Standards

ASME B16.34
ASME B16.10
ASME B16.5
API 607/API 6FA
API 6D

Alloy Valves and Control

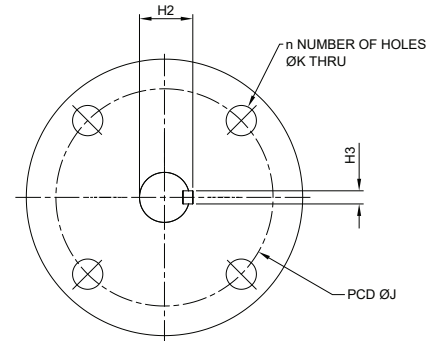
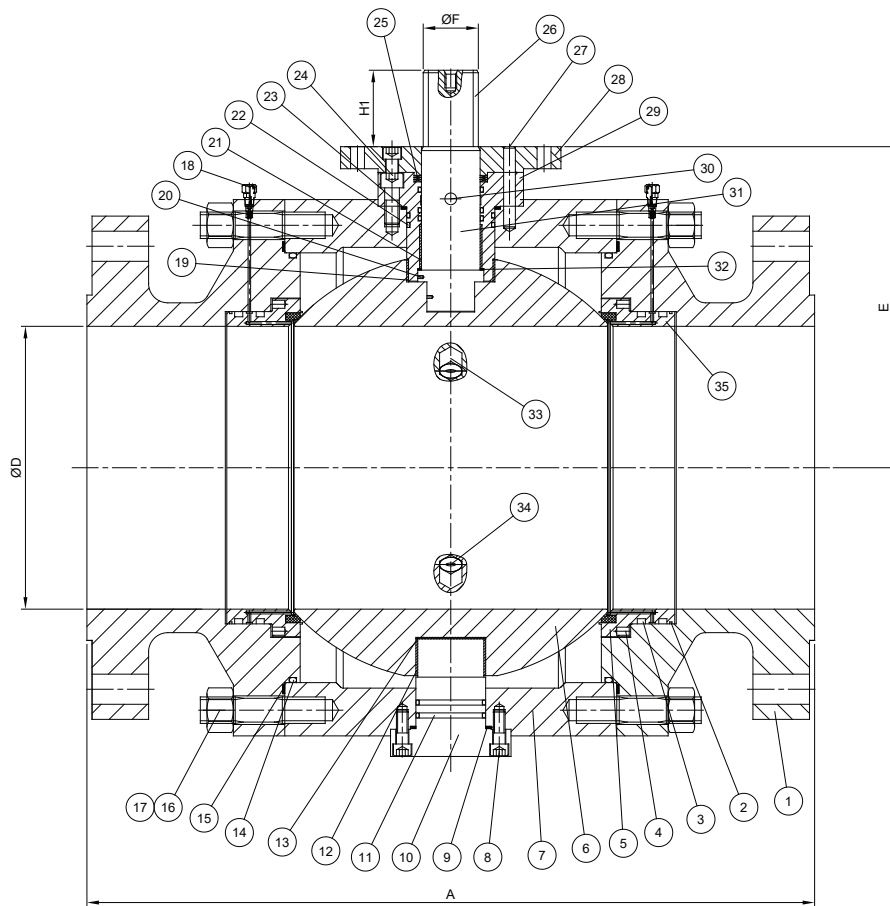

MOUNT PAD DETAIL (SINGLE KEY)
STEM DIAMETER <30mm

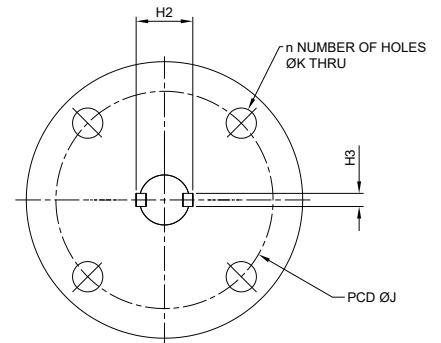

MOUNT PAD DETAIL (DOUBLE KEY)
STEM DIAMETER >30mm

ANSI Class 150 Dimensions

SIZE	A (mm)		D (mm)	E (mm)	F (mm)	H1 (mm)	H2 (mm)	H3 (mm)	J (mm)	K (mm)	n	ISO 5211	Weight (kg)	TORQUE (N.m)	CV
	RF Flanged	Butt Weld													
2"	178	216	49	115	20	30	22.5	6	102	11	4	F10	21	45	500
2 1/2"	191	241	62	128	24	36	27	8	102	11	4	F10	28	65	1050
3"	203	283	74	135	24	36	27	8	102	11	4	F10	35	100	1300
4"	229	305	100	175	28	42	31	8	125	14	4	F12	55	165	2300
6"	394	457	150	242	36	48	42	10	165	23	4	F16	164	400	5400
8"	457	521	201	290	40	60	46	12	165	23	4	F16	270	680	10000
10"	533	559	252	328	50	74	57	14	165	23	4	F16	440	1150	17800
12"	610	635	303	375	55	85	62	16	254	19	8	F25	635	1650	26000
14"	686	762	335	405	65	95	73	18	254	19	8	F25	850	2650	32000
16"	762	838	385	460	65	95	73	18	254	19	8	F25	1140	3350	44000
18"	864	914	436	498	75	115	84	20	254	19	8	F25	1450	4800	58000
20"	914	991	487	545	85	125	95	22	254	19	8	F25	1940	6400	75000
24"	1067	1143	589	640	95	130	105	25	298	23	8	F30	2805	11500	111200
28"	1245	1346	684	715	105	150	117	28	356	33	8	F35	4050	17000	143000

Alloy Valves and Control

ANSI Class 300 Dimensions

SIZE	A (mm)		D (mm)	E (mm)	F (mm)	H1 (mm)	H2 (mm)	H3 (mm)	J (mm)	K (mm)	n	ISO 5211	Weight (kg)	TORQUE (N.m)	CV
	RF Flanged	Butt Weld													
2"	216	216	49	115	20	30	22.5	6	102	11	4	F10	25	80	470
2 1/2"	241	241	62	128	24	36	27	8	102	11	4	F10	32	120	850
3"	283	283	74	135	24	36	27	8	102	11	4	F10	48	210	1100
4"	305	305	100	180	28	42	31	8	125	14	4	F12	80	360	2200
6"	403	457	150	238	36	48	42	10	165	23	4	F16	175	720	5400
8"	502	521	201	295	40	60	46	12	165	23	4	F16	295	1050	10000
10"	568	559	252	328	50	75	57	14	254	19	8	F25	510	1850	17100
12"	648	635	303	385	55	85	62	16	254	19	8	F25	758	2750	25000
14"	762	762	335	415	65	95	73	18	254	19	8	F25	975	3850	31000
16"	838	838	385	465	65	95	73	18	254	19	8	F25	1350	5150	42000
18"	914	914	436	510	75	115	84	20	254	19	8	F25	1715	6800	56000
20"	991	991	487	560	85	125	95	22	298	23	8	F30	2080	8350	72000
24"	1143	1143	589	655	95	130	105	25	298	23	8	F30	3850	15500	102000
28"	1346	1346	684	725	105	150	117	28	356	33	8	F35	4570	23000	123000

ANSI Class 600 Dimensions

SIZE	A (mm)		D (mm)	E (mm)	F (mm)	H1 (mm)	H2 (mm)	H3 (mm)	J (mm)	K (mm)	n	ISO 5211	Weight (kg)	TORQUE (N.m)	CV
	RF Flanged/ Butt Weld	RTJ Flanged													
2"	292	295	49	120	24	35	27	8	102	11	4	F10	33	165	400
2 1/2"	330	333	62	148	32	45	38	10	125	14	4	F12	52	280	875
3"	356	359	74	165	32	45	38	10	125	14	4	F12	65	340	1000
4"	432	435	100	198	32	53	38	10	125	14	4	F12	110	450	1800
6"	559	562	150	268	40	65	46	12	165	23	4	F16	285	1750	4500
8"	660	664	201	320	50	75	57	14	165	23	4	F16	470	2450	8900
10"	787	791	252	377	65	100	73	18	254	19	8	F25	760	3850	14500
12"	838	841	303	408	65	100	73	18	254	19	8	F25	1010	5800	22000
14"	889	892	335	430	75	110	84	20	254	19	8	F25	1350	8550	28000
16"	991	994	385	500	75	110	84	20	254	19	8	F25	1750	9500	39000
18"	1092	1095	436	560	85	130	95	22	298	23	8	F30	2285	15350	51000
20"	1194	1200	487	658	95	140	105	25	298	23	8	F30	2815	22000	66000
24"	1397	1407	589	685	115	170	129	32	356	33	8	F35	4920	31500	92000
28"	1549	1562	684	750	125	185	139	32	406	39	8	F40	6050	45000	122000

Alloy Valves and Control

ANSI Class 900 Dimensions

SIZE	A (mm)		D (mm)	E (mm)	F (mm)	H1 (mm)	H2 (mm)	H3 (mm)	J (mm)	K (mm)	n	ISO 5211	Weight (kg)	TORQUE (N.m)	CV
	RF Flanged/ Butt Weld	RTJ Flanged													
2"	368	371	49	132	28	45	31	8	125	14	4	F12	65	195	360
2 1/2"	419	422	62	165	32	50	38	10	125	14	4	F12	80	380	750
3"	381	384	74	178	38	58	44	10	125	14	4	F12	95	550	1000
4"	457	460	100	205	42	65	48	12	165	23	4	F16	154	950	1800
6"	610	613	150	280	50	75	57	14	165	23	4	F16	390	2150	4300
8"	737	740	201	338	65	100	73	18	254	19	8	F25	610	4000	8400
10"	838	841	252	392	75	115	84	20	254	19	8	F25	820	6450	14000
12"	965	968	303	425	75	115	84	20	298	23	8	F30	1125	9650	21000
14"	1029	1038	322	465	85	130	95	22	298	23	8	F30	1620	15500	26000
16"	1130	1140	373	520	95	140	105	25	298	23	8	F30	2010	18500	36000
18"	1219	1232	424	570	105	160	117	28	356	33	8	F35	2810	24500	47500
20"	1321	1334	471	602	115	175	129	32	356	33	8	F35	3460	31500	60000
24"	1549	1569	570	705	135	205	151	36	406	39	8	F40	5495	47500	86000

ANSI Class 1500 Dimensions

SIZE	A (mm)		D (mm)	E (mm)	F (mm)	H1 (mm)	H2 (mm)	H3 (mm)	J (mm)	K (mm)	n	ISO 5211	Weight (kg)	TORQUE (N.m)	CV
	RF Flanged/ Butt Weld	RTJ Flanged													
2"	368	371	49	155	28	45	31	8	125	14	4	F12	65	350	360
2 1/2"	419	422	62	175	32	50	38	10	140	19	4	F14	95	650	690
3"	470	473	74	195	38	58	44	10	165	23	4	F16	145	950	900
4"	546	549	100	225	48	72	55	14	165	23	4	F16	255	2500	1600
6"	705	711	144	275	55	85	63	16	254	19	8	F25	475	5500	4000
8"	832	841	192	325	75	115	84	20	254	19	8	F25	820	7450	7900
10"	991	1000	239	370	85	130	95	22	298	23	8	F30	1195	15500	13000
12"	1130	1146	287	420	100	150	112	28	298	23	8	F30	1970	16500	19000
14"	1257	1276	316	445	110	150	112	28	356	33	8	F35	2250	24000	24000
16"	1384	1407	360	510	120	180	134	32	356	33	8	F35	2760	34500	33000

ANSI Class 2500 Dimensions

SIZE	A (mm)		D (mm)	E (mm)	F (mm)	H1 (mm)	H2 (mm)	H3 (mm)	J (mm)	K (mm)	n	ISO 5211	Weight (kg)	TORQUE (N.m)	CV
	RF Flanged/ Butt Weld	RTJ Flanged													
2"	451	454	43	170	36	55	42	10	165	23	4	F16	90	950	285
2 1/2"	508	514	50	180	42	65	48	12	165	23	4	F16	160	1350	525
3"	578	584	63	205	48	72	55	14	165	23	4	F16	220	1800	825
4"	673	683	88	250	55	85	63	16	254	19	8	F25	385	2900	1510
6"	914	927	132	290	65	100	73	18	254	19	8	F25	775	6800	3590
8"	1022	1038	180	340	85	130	95	22	298	23	8	F30	1435	11000	7160

Notes Regarding Dimensional Tables

1. All dimensions in the above tables are for guidance only and can be subject to change dependant upon actual operating conditions and design parameters specified at point of sale. Accurate drawings are available for each valve size and can be supplied once an order is placed.
2. The torque values are based upon opening torque for soft seated (RPTFE seat or Nylon/Devlon Seat as per different size/class selection) valves at maximum differential pressure and clean gas or liquid conditions. No safety factor has been applied.
3. Metal seated versions have a torque approximately three times higher than that shown in the tables.
4. The torque values listed in the above table are at ambient temperature.
5. The torque values listed in the above table are to be used as a guide for actuator selction. A safety factor of 1.5 is suggested for actuator sizing.
6. Actual operating conditions should be accounted for when determining torque as they may have an impact on final operating torque.
7. All mount pads conform to ISO 5211.

Bi-directional Upstream Sealing

This valve is equipped with two spring energized seats which provide pre-loading and thereby effective sealing at low pressures. Sealing is enhanced at higher pressures as the upstream pressure creates a piston effect on the seat. Both seats are identical thus ensuring true bi-directional operation.

Anti-Static Design

A number of metal components are isolated by packing and bearing materials which can cause electrical conductance continuity to be lost. To overcome this, spring energized balls are installed to maintain continuity and prevent the possibility of sparking resulting from static.

Emergency Sealant System

Valve sizes 6" and above (smaller sizes upon request where design allows) are fitted with an injection system. This system enables the user to inject special sealing grease around the stem seals and seats to create an emergency temporary seal in the event of a fire or seal/seat failure.

Blow-Out Prevention Stem

The stem has an integral shoulder as part of the design to prevent blow-out if excess pressure is encountered during operation.

Fire-Safe Design

In the event of a fire, several safety features are in place to prevent leakage. The seats have a metal lip that is pushed against the ball after the main seat melts away to effect temporary sealing. The main external joints have spiral wound gaskets to withstand the high temperatures encountered during a fire.

Seat Design Variations

These valves are supplied with self relieving (single piston) seat designs as standard. These seats also act as double block and bleed when the ball is in the closed position via the vent or drain port. Double piston effect seat design is available upon request and is suggested to be used in conjunction with a body cavity relief valve.

Item	Description	Materials				
		Carbon Steel	Sulfur Proof	304 Stainless Steel	316 Stainless Steel	LF2
1	End Caps	A105	A105	A182-F304, F304L	A182-F316, F316L	A350-LF2
2	Seat Ring Gasket	304 or 316 + Graphite				
3	Seat Ring O-Ring	Viton, HNBR				
4	Seat Ring Spring	304, 316, 17-7PH, X-750				
5	Seat	RPTFE, Nylon, PEEK, Devlon, Metal				
6	Ball	A105 + ENP	A105 + ENP	304, 304L	316, 316L	304, 316, LF2+ENP
7	Body	A105	A105	A182-F304, F304L	A182-F316, F316L	A350-LF2
8	Plug Screw	A193-B7	A193-B7M	A193-B8/B8M	A193-B8/B8M	A350-L7
9	Plug Gasket	304 or 316 + Graphite Spiral Wound				
10	Plug	A105	A105	304, 304L	316, 316L	304, 316
11	Plug O-Ring	Viton, HNBR				
12	Ball Bearing Sleeve	304 or 316 + PTFE				
13	Thrust Bearing	PTFE				
14	Body O-Ring Seal	Viton, HNBR				
15	Body Gasket	304 or 316 + Graphite Spiral Wound				
16	Body Stud	A193-B7	A193-B7M	A193-B8/B8M	A193-B8/B8M	A350-L7
17	Body Nut	A194-2H	A194-2HM	A194-8/8M	A194-8/8M	A194-7
18	Seat Grease Fitting	Assembly				
19	Ball Bearing Sleeve	304 or 316 + PTFE				
20	Anti-Static Device	Assembly				
21	Stem Bearing Sleeve	304 or 316 + PTFE				
22	Seal Cover O-Rings	Viton, HNBR				
23	Seal Cover Gasket	304 or 316 + Graphite Spiral Wound				
24	Screw	A193-B7	A193-B7M	A193-B8/B8M	A193-B8/B8M	A350-L7
25	Stem Packing	Graphite				
26	Key	AISI 1045				
27	Shear Pin	ASTM A276-420				
28	Mount Pad	A105	A105	A182-F304, F304L	A182-F316, F316L	A350-LF2
29	Seal Cover	A105	A105	A182-F304, F304L	A182-F316, F316L	A350-LF2
30	Stem Grease Fitting	Assembly				
31	Stem	A182-F6a	A182-F6a	A182-F304, F304L	A182-F316, F316L	A182-F304, F316, F6a
32	Thrust Washer	PTFE				
33	Vent Valve	Assembly				
34	Drain Valve	Assembly				
35	Seat Ring	A105 + ENP	A105 + ENP	A182-F304, F304L	A182-F316, F316L	F304, F316, LF2 + ENP

Alloy Valves and Control

Pressure/Temperature Rating
for Class 150, 300 & 600

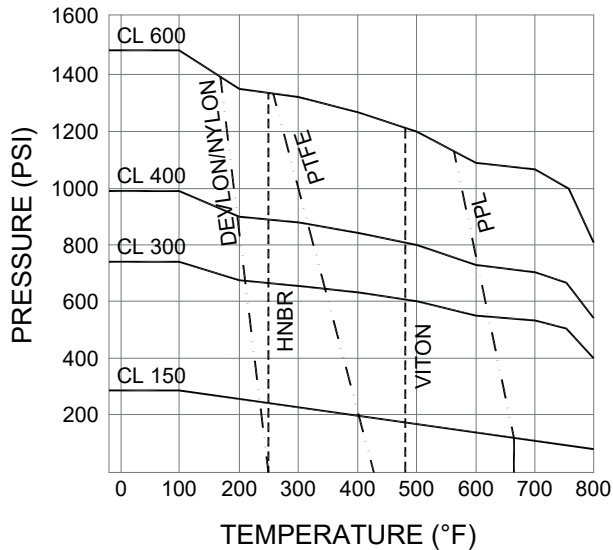

Pressure/Temperature Rating
for Class 900 & 1500

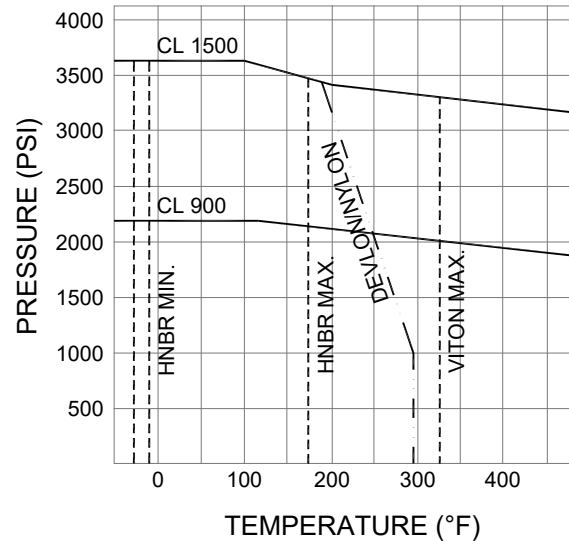

Notes Regarding Pressure/Temperature Graphs

- The above graphs represent just some of the seat/seal combinations available covering typical applications. Please contact sales@avcovalve.com for conditions not shown above.

HOW TO ORDER

111	3	3	R	V	150	200	SP
Series	Body & End Material	Ball & Stem Material	Seat Material	Seal Material	End Style	Size	Options
11100 Series 3 Piece Forged Fire-Safe Full Port Trunnion Mounted Ball Valve	1 - Carbon Steel 3 - 316 SS J - 304 SS U - LF2	1 - Carbon Steel 3 - 316 SS J - 304 SS Y - ENP (Nickel)	D - Devlon M - Metal N - Nylon P - PEEK R - 15% Glass PTFE	B - Buna G - Graphoil H - HNBR T - Teflon V - Viton	150 - 150# Flange 300 - 300# Flange 600 - 600# Flange 900 - 900# Flange 1500 - 1500# Flange 2500 - 2500# Flange BW - Butt Weld SW - Socket Weld	200 - 2" 250 - 2 1/2" 300 - 3" 400 - 4" 600 - 6" 800 - 8" 1000 - 10" 1200 - 12" 1400 - 14" 1600 - 16" 1800 - 18" 2000 - 20" 2400 - 24" 2800 - 28"	SP - Sulfur Proof