

# AVCO

*Alloy Valves and Control*

## BALL VALVES 1800 SERIES



### Size

1/4" - 4"  
1500 or 2000 WOG (size dependent)  
Up to ASME B16.34 class 600

### End Connections

NPT  
Butt Weld  
Socket Weld  
Flanged (150#, 300#, 600#)

### Valve Materials

316 Stainless Steel  
Carbon Steel  
Hastelloy C  
Monel  
Alloy 20  
Duplex/Super Duplex

### Ball and Stem Materials

316 Stainless Steel  
Hastelloy C  
Monel 400  
Alloy 20  
Duplex/Super Duplex

### Seat Materials

Teflon (PTFE)  
25% Carbon Filled Teflon  
15% Glass Filled Teflon  
Kel-F® (PCTFE)  
PEEK  
TFM (Cavity Filled Option)  
UHMWPE  
Metals

### Service Applications

Chemical  
Dry/Liquid Chlorine  
Food Processing  
Hydraulic  
Oxygen  
Steam  
Thermal Fluids  
Vacuum  
Water/Oil/Gas

### Applicable Standards

ASME B16.34  
API 598  
CRN (All Provinces)  
NACE MR0175/ISO 15156

***Alloy Valves and Control*****About the 1800 Series Ball Valve**

The AVCO 1800 series side entry diverter ball valve brings high quality and performance to the diverter and mixing valve market. Using a 90-degree diverter ball allows the valve to flow different media into a common port and is often used for flushing lines or as a common valve into a mixing tank. When installed with a V ported ball it offers metered mixing into a common line. The stem is live loaded with blow out prevention and has online adjustment capability. Sealing occurs at the thrust washer inside the body to reduce the potential for leakage. Locking levers give positive diversion or shut-off and the ISO 5211 mount pad allows for many actuators, limit switches and positioners to be mounted with ease. Available with all the same options as most of our entire 1000 series range, these valves offer flexibility in materials and end styles for use in many applications. This valve series is truly at home in the oil, gas, petroleum and food processing industries, meeting the highest standards such as ASME B16.34 & API 598.

**Design**

- The valve body has four cast sections (three for flanged versions) comprising body and three end caps.
- Valves are available up to class 600 per ASME B16.34 or 2000 WOG.
- The sections are bolted together and conform to ASME B16.34.
- The end to end dimensions conform to ASME B16.10 for most flanged versions and to AVCO standards for all other styles.
- Butt weld ends conform to ASME B16.25.
- Flange ends conform to ASME B16.5.
- Threaded ends conform to ASME B1.20.1, B16.11 & B16.34.
- Socket weld ends conform to ASME B16.11 & B16.34.
- The seats are encapsulated for greater durability.
- The valve is designed for minimal pressure drop across the valve.
- The valve body has an integral mounting pad conforming to ISO 5211.
- The stem is bottom entry and has blow-out prevention.
- The body gasket material is available in several materials to cover different media types.
- The seat material is available in several materials to cover different media types.
- The stem assembly enables online adjustment of the packing.
- The valves are tested to API 598 and ASME B16.34.
- Valve sizes 1/4" thru 4" are available in butt weld, socket weld & threaded ends.
- Valve sizes 1/2" thru 4" are available in flanged ends.
- The 90° ball offers diversion and mixing capabilities.

**Operation**

The following operators can be utilized on the valve:

- Various manual handles (Lever, Tee, Oval).
- Chain wheel operator.
- Worm Gear operator.
- Pneumatic actuator.
- Hydraulic actuator.
- Electric motor actuator.

### Alloy Valves and Control

#### 1/4" THRU 2" (NPT, BW, SW)

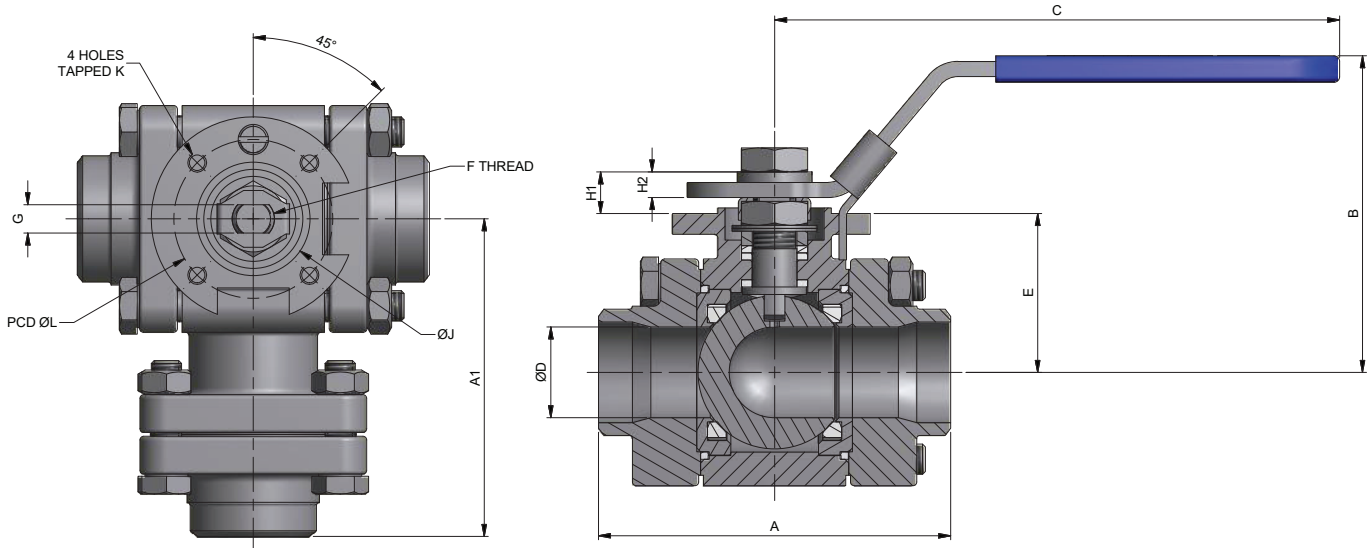

Plan View with Handle Removed

SIZE	A (in.)	A1 (in.)	B (in.)	C (in.)	D (in.)	E (in.)	F (in.)	G (in.)	H1 (in.)	H2 (in.)	J (in.)	K	L (in.)	ISO 5211	Cv	Weight (lbs)
1/4"	2.61	2.72	2.48	4.53	0.36	1.240	3/8-24 UNF	0.224	0.524	0.344	0.984	M5	1.417	F03	3.5	2.3
3/8"	2.61	2.72	2.48	4.53	0.49	1.240	3/8-24 UNF	0.224	0.524	0.344	0.984	M5	1.417	F03	6	2.3
1/2"	2.97	2.90	2.48	4.53	0.59	1.240	3/8-24 UNF	0.224	0.524	0.344	0.984	M5	1.417	F03	6	2.3
3/4"	3.17	3.05	2.56	4.53	0.75	1.319	3/8-24 UNF	0.224	0.524	0.344	0.984	M5	1.417	F03	8.5	3.6
1"	3.67	3.31	3.38	5.91	0.95	1.654	7/16-20 UNF	0.295	0.654	0.478	1.181	M5	1.654	F04	17	5.2
1 1/4"	4.37	3.93	3.50	5.91	1.18	1.850	7/16-20 UNF	0.295	0.654	0.478	1.181	M5	1.654	F04	22	8.4
1 1/2"	4.72	4.23	3.92	6.85	1.50	1.909	9/16-18 UNF	0.339	1.122	0.660	1.378	M6	1.969	F05	40	11.0
2"	5.53	4.85	4.25	6.85	1.97	2.264	9/16-18 UNF	0.339	1.122	0.660	1.378	M6	1.969	F05	72	17.6

#### 1/2" THRU 2" (Standard Flanged Ends 150#, 300#, 600#)

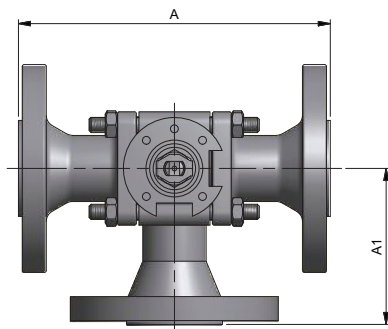

SIZE	A (in.)			A1 (in.)		
	150#	300#	600#	150#	300#	600#
1/2"	5.50	5.50	6.50	2.75	2.75	3.25
3/4"	6.00	6.00	7.50	3.00	3.00	3.75
1"	6.50	6.50	8.50	3.25	3.25	4.25
1 1/4"	7.00	7.00	9.00	3.50	3.50	4.50
1 1/2"	7.50	7.50	9.50*	3.75	4.33	4.75*
2"	8.50	8.50	11.50*	4.25	4.75	5.75*

See main table on this page for all other dimensions

#### Note (also applies to next page)

Flanged ends are raised face per ASME B16.5. End to end dimensions meet AVCO standard. Please contact AVCO if you require flanged ends other than raised face or custom end to end dimensions.

\* Valve sizes 1 1/2" thru 4" with class 600 flanges do not meet ASME B16.34.

### Alloy Valves and Control

**2 1/2" (FLANGED 150#, 300#, 600#)**  
Contact AVCO for NPT, BW & SW versions

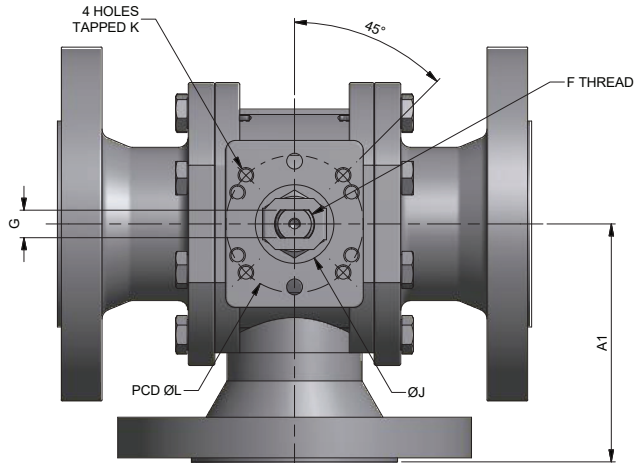

Plan View with Handle Removed

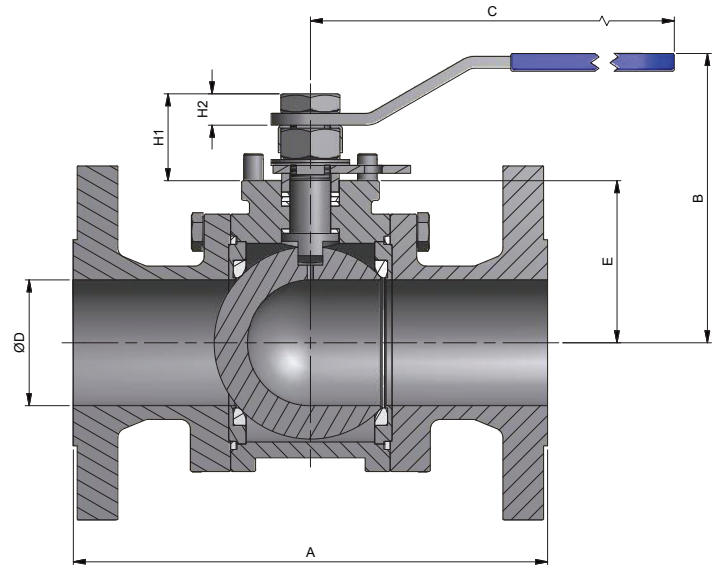

SIZE	A (in.)			A1 (in.)			B (in.)	C (in.)	D (in.)	E (in.)	F (in.)	G (in.)	H1 (in.)	H2 (in.)	J (in.)	K (in.)	L (in.)	ISO 5211	Cv	Weight (lbs)
	150#	300#	600#	150#	300#	600#														
2 1/2"	9.50	9.50	13.00*	4.75	5.75	6.50*	5.28	8.84	2.52	3.248	M20	0.551	1.673	0.728	1.575	M8	2.756	F07	86	48

**3" & 4" (FLANGED 150#, 300#, 600#)**  
Contact AVCO for NPT, BW & SW versions

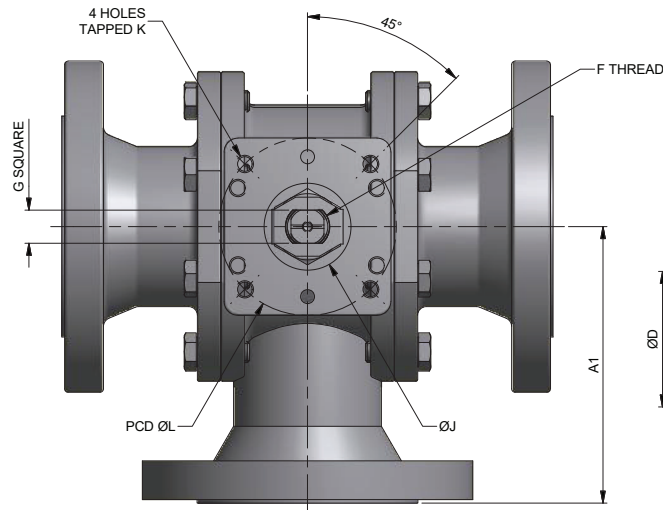

Plan View with Handle Removed

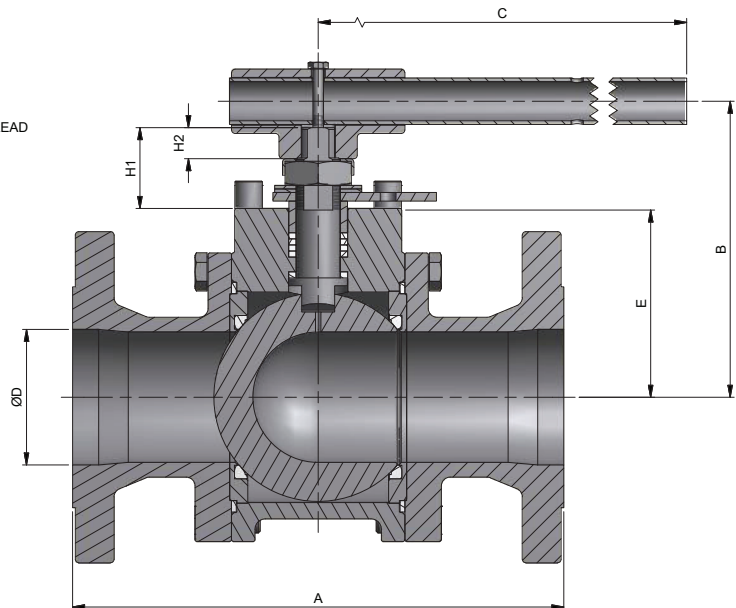

SIZE	A (in.)			A1 (in.)			B (in.)	C (in.)	D (in.)	E (in.)	F (in.)	G (in.)	H1 (in.)	H2 (in.)	J (in.)	K (in.)	L (in.)	ISO 5211	Cv	Weight (lbs)
	150#	300#	600#	150#	300#	600#														
3"	11.12	11.12	14.00*	6.25	6.25	7.00*	6.84	13.74	2.95	4.276	1-14	0.748	1.823	0.685	1.969	M10	4.016	F10	163	72
4"	12.00	12.00	17.00*	7.25	7.25	8.50*	7.37	13.74	3.78	4.807	1-14	0.748	1.823	0.685	1.969	M10	4.016	F10	223	103

### Alloy Valves and Control

#### Valve Pressure Ratings

The AVCO 1800 series ball valve can be supplied with WOG or ASME B16.34 pressure ratings. ASME B16.34 restricts the allowable bolt stress to 20,000 psi, whereas WOG has no restrictions on bolting allowing us to achieve greater pressure ratings within the same valve pattern. The WOG rated valves also use the standardized ASME allowable stress values to determine wall thickness, thereby resulting in a safe and reliable design. For ASME B16.34 rated valves, the 1800 series is fully compliant when used within the pressure/temperature limits defined on the next page.

The pressure ratings are available as follows:

#### WOG Ratings

2000 WOG - 1/4" thru 2"  
1500 WOG - 2 1/2" thru 4"

#### ASME B16.34 Ratings

Class 600 - 1/4" thru 1 1/4"  
Class 300 - 1 1/2" thru 4"

Unless otherwise requested, the 1800 series will be supplied with WOG ratings on the valve tag.

Pressure/Temperature Rating Graph for WOG rated valves

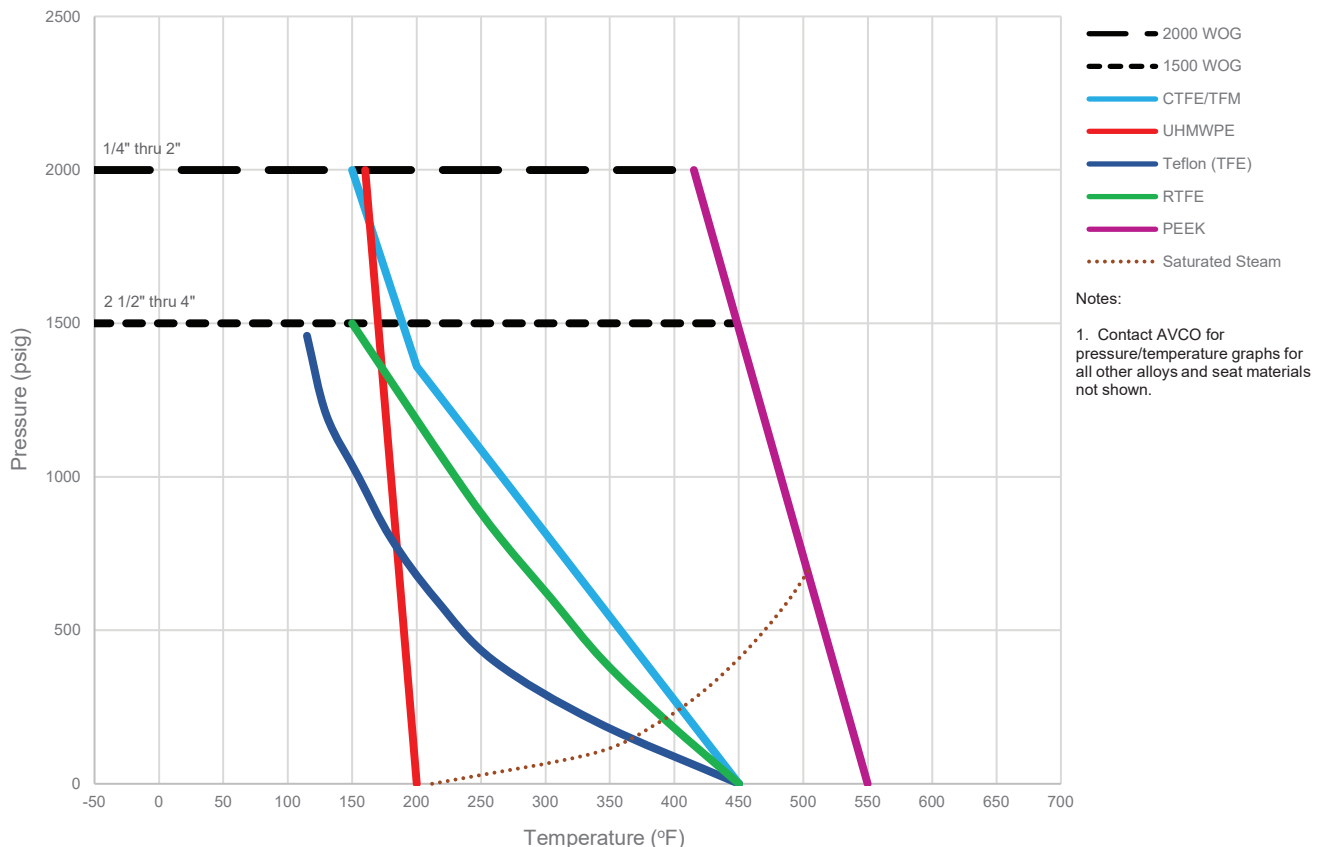

Pressure/Temperature Rating Graph Per ASME B16.34

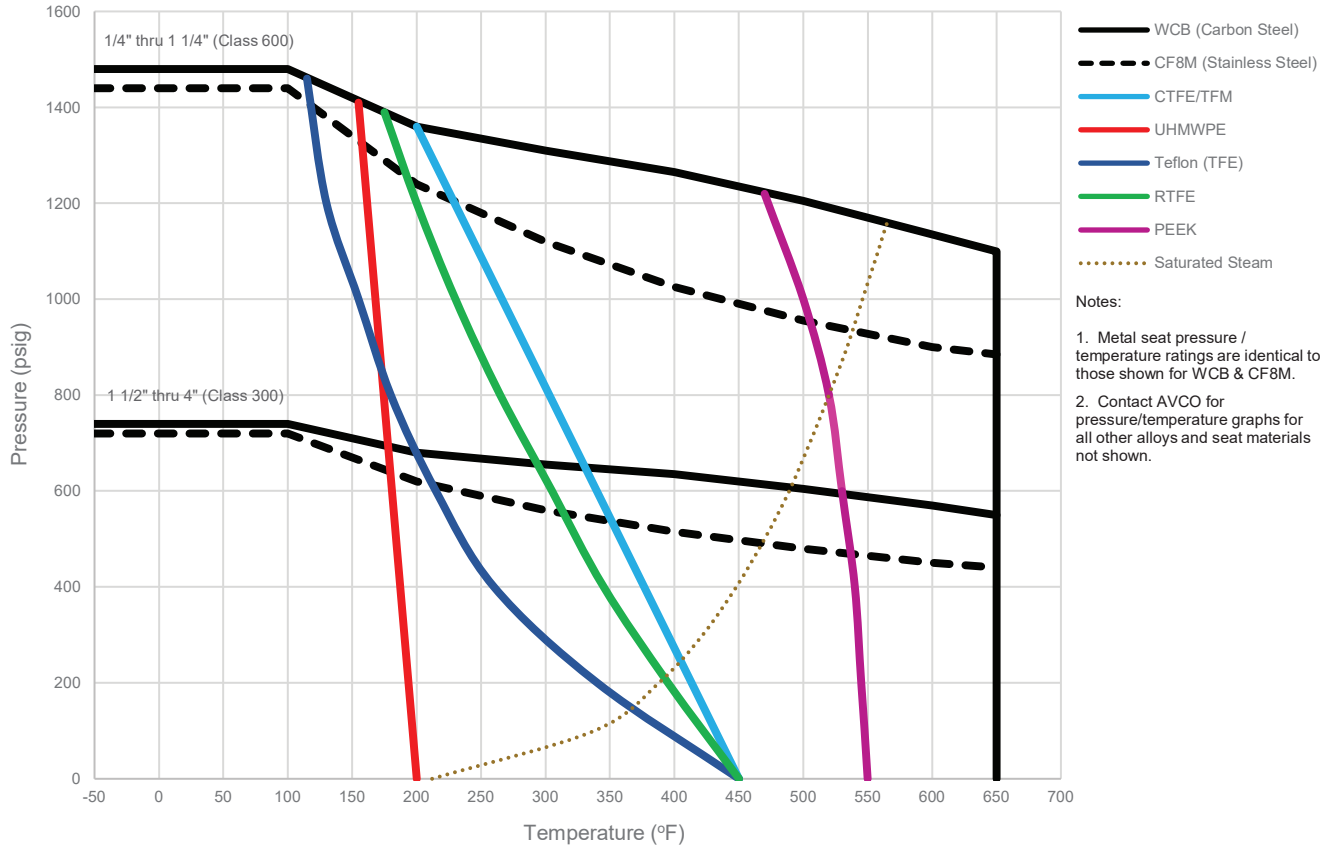

Torque Table (in.lbs)

SEAT MATERIAL	1/4"	3/8"	1/2"	3/4"	1"	1 1/4"	1 1/2"	2"	2 1/2"	3"	4"
TFE	30	30	30	60	90	140	150	650	900	1000	1100
TFM	30	30	30	40	55	125	135	600	900	1000	1700
RTFE	30	30	30	75	80	175	225	800	1000	1100	1450
CTFE	78	78	78	110	160	240	500	900	1000	1620	2750
UHMWPE	140	140	140	150	160	220	360	720	840	1560	1860
PCTFE	205	205	205	220	230	265	1000	1380	1450	2600	3000
PEEK	160	160	160	170	360	700	720	900	1200	2100	3800
METAL	130	130	130	250	390	600	650	800	1500	3700	3800

**Notes**

- Torque shown is actual measured maximum values, using water, at the maximum valve pressure rating and ambient temperature. Actual operating conditions and media type will affect torque values. If in doubt, please contact AVCO.

*Alloy Valves and Control*

1/4" THRU 3/4"

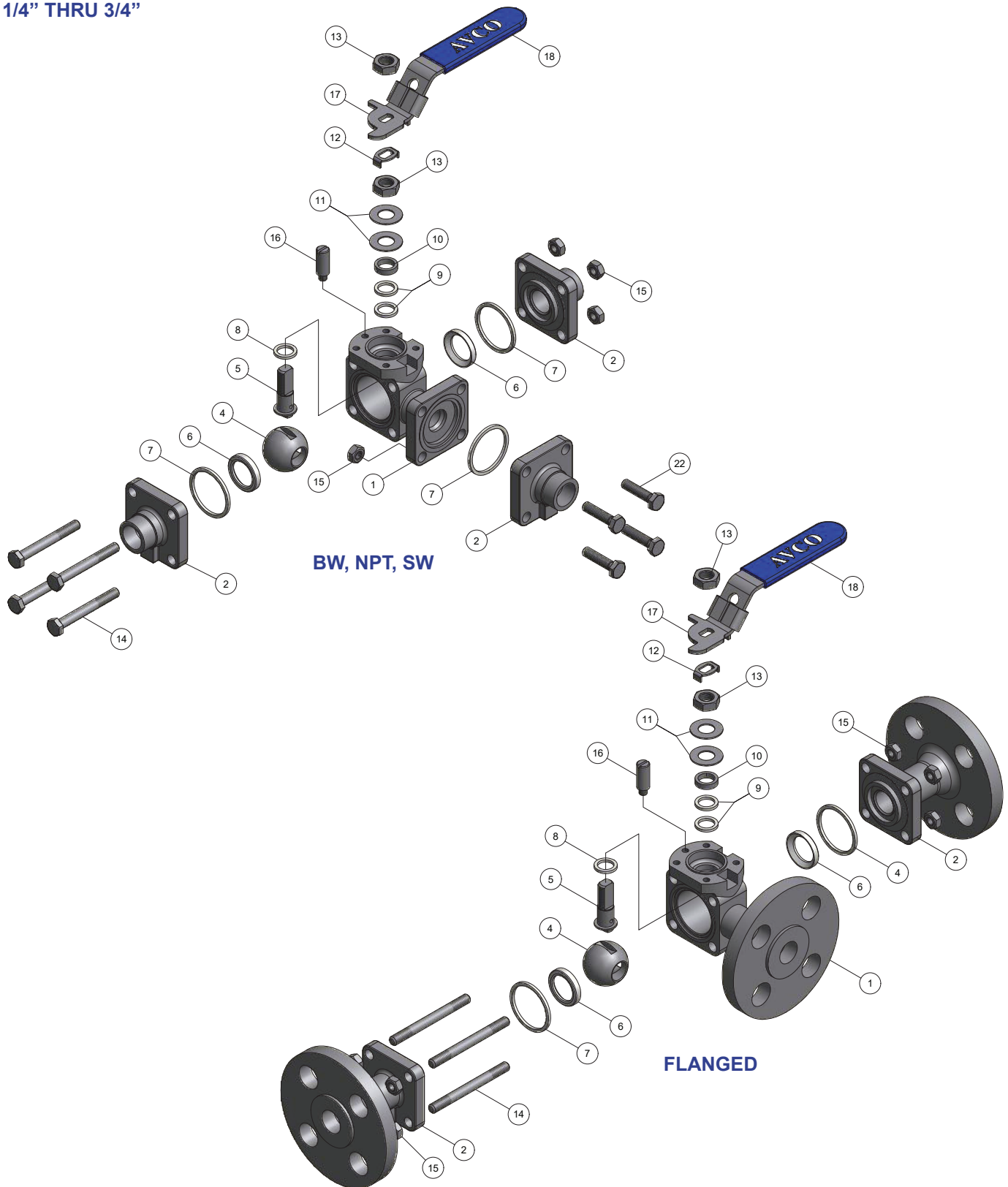

*Alloy Valves and Control*

1" THRU 2"

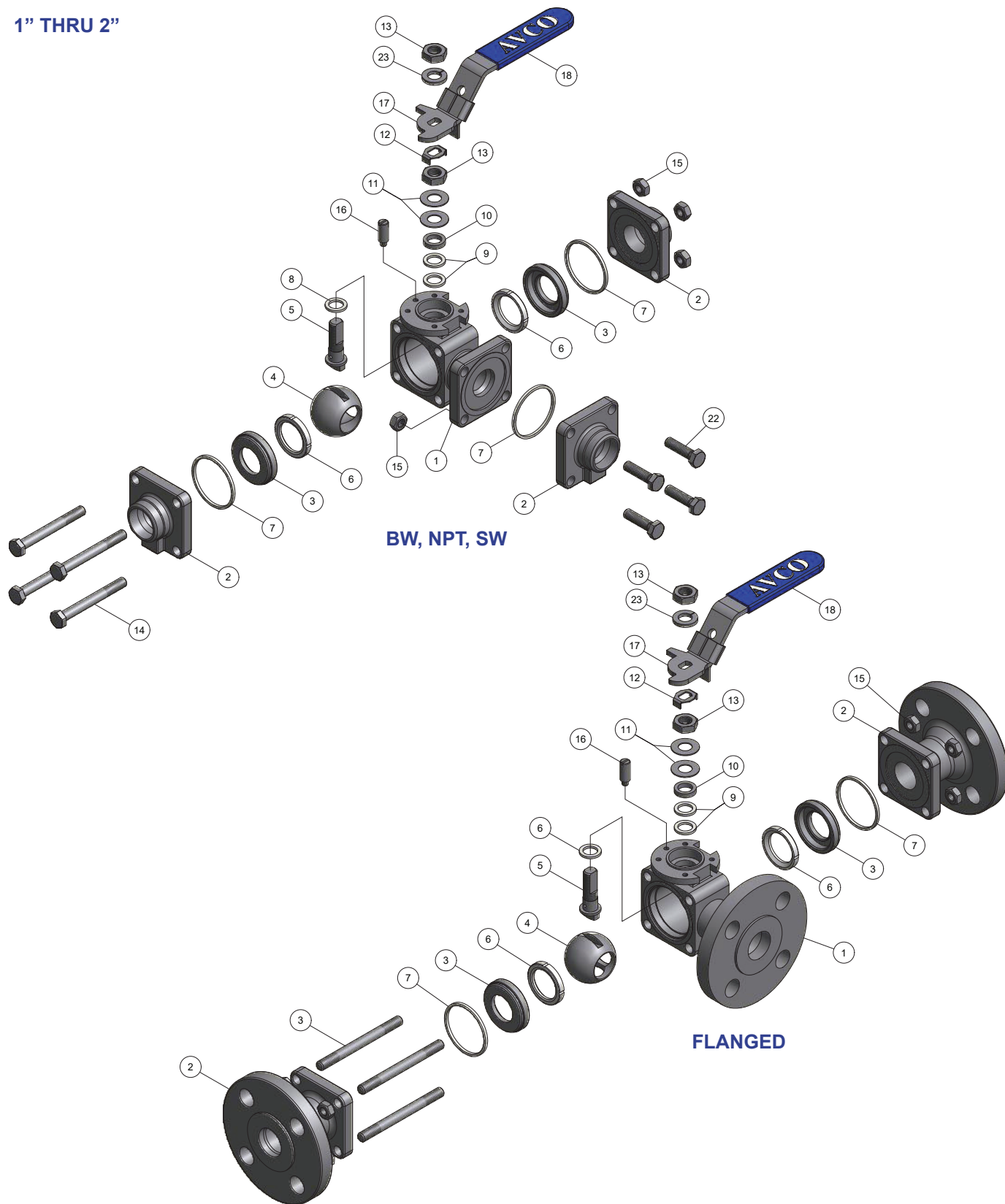

**BW, NPT, SW**

**FLANGED**



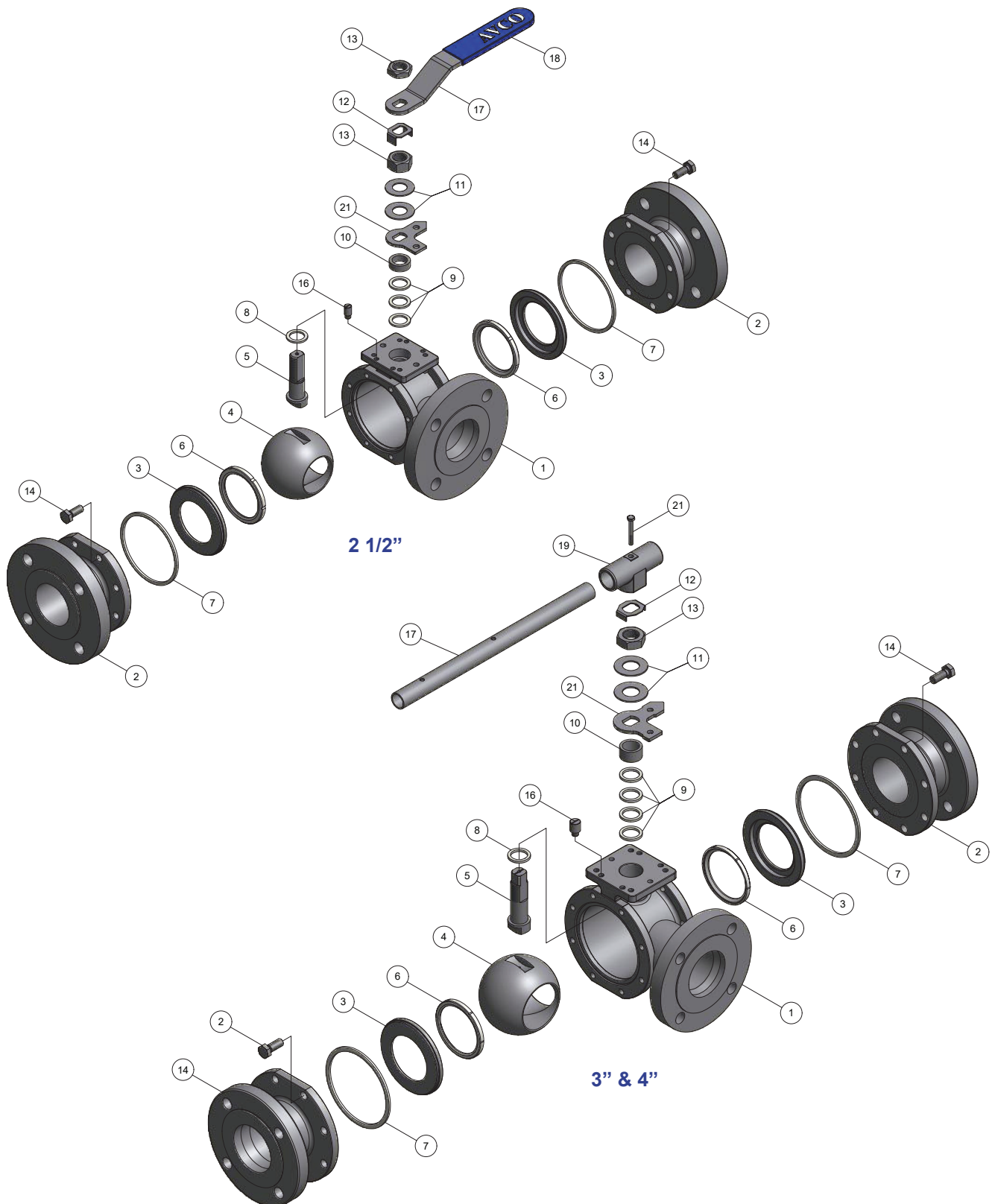

Item	Description	Included in Valve Assembly				Material	
		1/4" thru 3/4"	1" thru 2"	2 1/2"	3" thru 4"	Stainless Steel	Carbon Steel
1	Body	Yes	Yes	Yes	Yes	A351 CF8M	A216 WCB
2	End Cap	Yes	Yes	Yes	Yes	A351 CF8M	A216 WCB
3	Retainer	No	Yes	Yes	Yes	A276 316	A276 316
4	Ball	Yes	Yes	Yes	Yes	A276 316	A276 316
5	Stem	Yes	Yes	Yes	Yes	A276 316 or ASTM A594 17-4	A276 316 or ASTM A594 17-4
6	Seat	Yes	Yes	Yes	Yes	Varies by Trim	Varies by Trim
7	Body Seal	Yes	Yes	Yes	Yes	Varies by Trim	Varies by Trim
8	Thrust Washer	Yes	Yes	Yes	Yes	Varies by Trim	Varies by Trim
9	Packing	Yes	Yes	Yes	Yes	Varies by Trim	Varies by Trim
10	Gland Ring	Yes	Yes	Yes	Yes	A276 316	A276-316
11	Disc Spring	Yes	Yes	Yes	Yes	Stainless Steel	Stainless Steel
12	Lock Washer	Yes	Yes	Yes	Yes	Stainless Steel	Stainless Steel
13	Stem Nut	Yes	Yes	Yes	Yes	Stainless Steel	Stainless Steel
14	Body Bolt	Yes	Yes	Yes	Yes	A2-70 or A193 B8	A2-70 or A193 B8
15	Body Nut	Yes	Yes	No	No	A2-70 or A194 2H	A2-70 or A194 2H
16	Stop Pin	Yes	Yes	Yes	Yes	Stainless Steel	Stainless Steel
17	Handle	Yes	Yes	Yes	No	Stainless Steel	Stainless Steel
18	Handle Sleeve	Yes	Yes	Yes	No	Vinyl	Vinyl
19	Wrench Block	No	No	No	Yes	Stainless Steel	Stainless Steel
20	Handle Bolt	No	No	No	Yes	Stainless Steel	Stainless Steel
21	Stop Pad	No	No	Yes	Yes	Stainless Steel	Stainless Steel
22	End Cap Bolt	Yes	Yes	No	No	A2-70 or A193 B8	A2-70 or A193 B8
23	Handle Washer	No	Yes	No	No	Stainless Steel	Stainless Steel

### Maintenance & Repair

The AVCO 1800 series ball valve is a very reliable and robust design, but as with all resilient seated valves, the 'soft' parts are subject to wear over time. Replacing a whole valve is an unnecessarily high cost and as such, the 1800 series is fully repairable while in-line. Repair and maintenance kits are usually available for same day shipping and are easy to install when following the IOM manual.

AVCO is committed to ensuring repair and maintenance kits are available for your valves for many years service and even when we make design improvements to our products, we ensure all changes are backwards compatible.

### *Alloy Valves and Control*

#### Flow Plans

The only Flow Plan available is shown below. The Flow Plan is shown as viewed from the top of the valve with clockwise rotation (as viewed from above) based upon manual operation. '0' denotes the starting position of the sequence for clockwise rotation.

**\*\*\*IMPORTANT\*\*\*** The Flow Plan sequences will be reversed with '90' being the starting position for most pneumatic and electric actuators. Contact AVCO if actuated clockwise rotation as shown below is required.

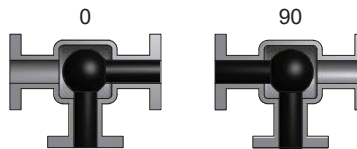

**FLOW PLAN 1**  
**3 Way L-Port - 90°**

### OPTIONAL FEATURES

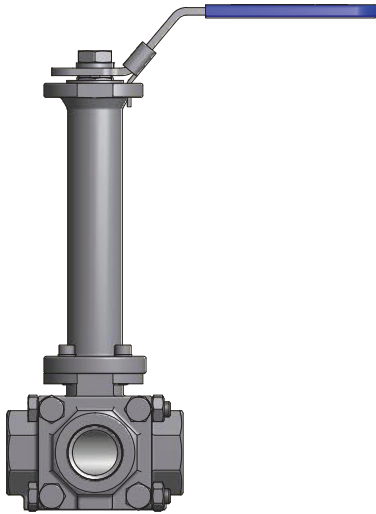

#### **Cryogenic Option**

The AVCO 1000 series ball valves are available for cryogenic service with an extended bonnet. The extended bonnet can be shortened or lengthened to suit many applications and is also available 'off the shelf' in standard lengths. Most options and end styles available for the regular 1800 series valves are also available for the 1500 series valves.

*[Click here for more information.](#)*

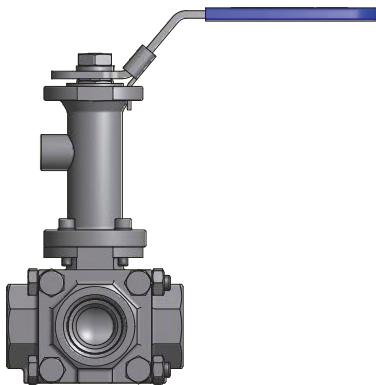

#### **Fugitive Emissions Option**

The AVCO 1000 series ball valves can be supplied with fugitive emissions (sniffer) bonnets. These bonnets give an early warning system when the valve stem packing is becoming worn and ready for adjustment or renewal, thus preventing dangerous chemicals/gases from entering the surrounding environment.

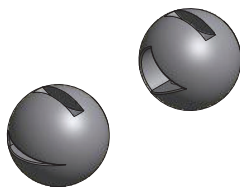

#### **Characterized Ball Option**

The AVCO 1000 series ball valves can be supplied with vee port or slotted balls for greater control and accuracy. Many configurations are available to suit the needs of the customer to produce the required flow characteristics.

*[Click here for more information.](#)*



### Electric Actuator

120 VAC  
12/24 VDC  
NEMA 4/7  
Positioners 4-20 mA  
Reversing  
Telemetry  
Battery Back-up  
Spring Return



### Pneumatic Actuator

Double Acting  
Spring Return  
Solenoid Valves  
Limit Switches  
Positioners 3-15 psi  
Positioners 4-20 mA  
Intelligent Positioner  
Declutchable Manual Override



### Manual Valves

Lever Handle  
Oval Handle  
Spring Return  
Fusible Link  
Lock Device  
Gear Operators

## HOW TO ORDER

18	3	3	T	T	SE	100	3L90-LH
Series	Body & End Material	Ball & Stem Material	Seat Material	Seal Material	End Style	Size	Options
1800 Series 3 Piece Side Entry Diverter Ball Valve	1 - Carbon Steel	2 - Alloy 20	T - Teflon (PTFE)	T - Teflon (PTFE)	SE - NPT	025 - 1/4"	3L90 - 90° Rotation Ball
	2 - Alloy 20	3 - 316 SS	R - 15% Glass PTFE	C - 25% Carbon PTFE	SW - Socket Weld	038 - 3/8"	BAHL - Hardened Ball
	3 - 316 SS	4 - Monel 400	C - 25% Carbon PTFE	G - Graphoil	BW - Butt Weld	050 - 1/2"	IE - Emissions Bonnet
	4 - Monel 400	6 - Hastelloy C	P - PEEK	U - UHMWPE	GR - Grooved	075 - 3/4"	CF - Cavity Filled
	6 - Hastelloy C	8 - Titanium	U - UHMWPE		AN - SAE 4395	100 - 1"	LH - Locking Lever Handle
	8 - Titanium	9 - Aluminum	K - Kel-F (PCTFE)		150 - 150# Flange	125 - 1 1/4"	OH - Oval Handle
	9 - Aluminum	E - Super Duplex	S - Stellite		300 - 300# Flange	150 - 1 1/2"	O2CB - O2 Clean/Bagged
	E - Super Duplex (2507)	G - Duplex	E - TFM		600 - 600# Flange	200 - 2"	
	G - Duplex (2205)		D - Delrin		AS5202 - SAE Ends	250 - 2 1/2"	
					Variations of the above or special ends can be supplied upon request	300 - 3" 400 - 4"	Customized Ports are available upon request

### Example ordering codes:

1833TT-SE-100-3L90-LH = 1" ball valve with stainless steel body/ball, Teflon seats/seals, NPT ends, 90° Rotation Ball & locking lever handle  
1844PG-150-100-3L90 = 1" ball valve with Monel 400 body/ball, PEEK seats, Graphoil Seals, 150# RF Flange, 90° Rotation Ball and bare stem

Copyright © 2014 Alloy Valves and Control Inc. All rights reserved. No part of this brochure may be used or reproduced in any manner whatsoever without written permission from AVCO

This brochure is general in nature and we reserve the right to alter dimensions, materials or make design improvements.