

AVCO

Alloy Valves and Control

BALL VALVES 1500 SERIES

INSTALLATION, OPERATION & MAINTENANCE MANUAL



This manual covers the installation, operation and maintenance of all AVCO standard 1500 series ball valves as described in the current AVCO catalog. Custom made or customer modified versions of the 1500 series may use this manual as a general guide only.

Alloy Valves and Control

1 General Design

- 1.1 AVCO Ball valves have been designed and engineered to provide long lasting and trouble free service when used in accordance with the instructions and recommendations detailed in this manual.
- 1.2 The valves may be installed for uni-directional flow or vacuum and should only be installed in horizontal pipe runs. Please contact AVCO directly if a 1500 series valve has to be installed in a vertical pipe run. The valves must never be installed with the handle or operator on the underside of the pipe and AVCO advises that, where possible, the valve handle be no more than 45° from top dead center when installed in a horizontal pipe run, particularly when an actuator other than a manual handle is used.

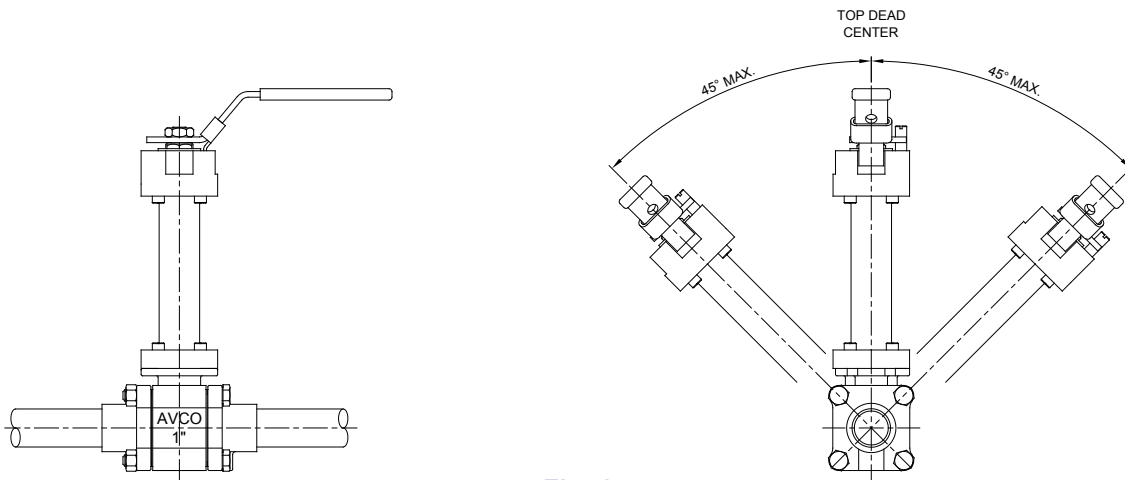

Fig. 1
Typical Valve Installations

2 Installation of Flanged and Threaded Valves

- 2.1 Refer to section 10 for instructions as to how to correctly determine whether the vent in the ball should be upstream or downstream and install as appropriate.
- 2.2 Do not dismantle these valves when installing as they should be treated as a unit.
- 2.3 Be sure not to overtighten taper threads.
- 2.4 Flanged valves should be bolted and gasketed in accordance with relevant standards.
- 2.5 If a threaded valve is 'back welded' after installation it should be treated as a weld end valve and dismantled prior to welding in accordance with section 3.

3 Installation of Weld End Valves

- 3.1 Refer to section 10 for instructions as to how to correctly determine whether the vent in the ball should be upstream or downstream and install as appropriate.
- 3.2 Prepare a clean working area.
- 3.3 With the valve in the open position, remove the body bolts or screws.
- 3.4 Separate the end caps from the body and remove the retainer rings (integral with end cap on sizes up

Alloy Valves and Control

to 3/4"), body seals (discard body seals) and seats whilst taking care not to damage the plastic parts. The ball can be placed in a part open position to assist removal of the seats.

- 3.5 Whilst supporting the ball to prevent it dropping out and potentially damaging the ball surface, rotate the valve to the closed position and remove the ball.
- 3.6 The ball, seats and retainer rings should be placed in a suitably remote clean area to minimize risk of damage whilst welding is being undertaken.
- 3.7 Reassemble the end caps onto the body with the appropriate body bolts or screws and position the valve in its relevant location and secure appropriately in readiness for welding.

NOTE: AVCO Supplies butt weld end caps in sch 10, sch 40 & sch 80 as standard and recommends that the adjoining pipe be the same schedule as that of the end cap to ensure an effective and even weld.

- 3.8 With the valve in its relevant position TACK WELD with minimum weld sufficient to hold its location unaided.
- 3.9 After the tack weld has suitably cooled, remove the body bolts or screws and ease the body from between the two end caps whilst taking care not to damage the mating surfaces.
- 3.10 Protect the end cap faces and finish weld the end caps to the pipe.
- 3.11 When cooled, clean the end cap faces and remove any weld spatter from inside the welded joint.

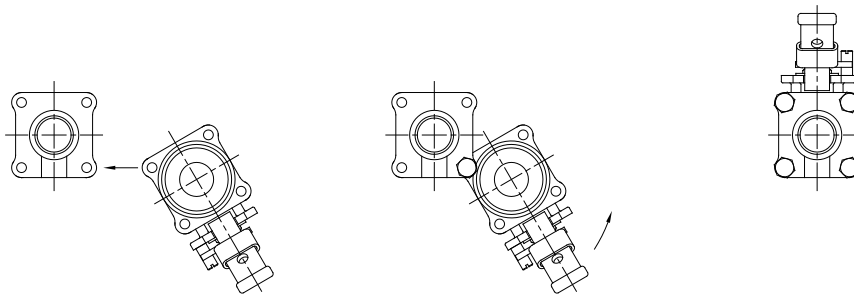

Fig. 2
Valve Body Installation Procedure
(Non-Cryogenic show as example)

- 3.12 Replace the ball into the valve body (whilst in closed position and considering section 10 for vent location) and carefully rotate to the open position. Replace the seats and retainer rings and insert new body seals (supplied).
- 3.13 Ease the completed body assembly (as shown below for sizes up to 2" inclusive) between the end caps ensuring that the faces and body seals are not trapped or damaged.
- 3.14 Insert body bolts or screws and tighten to the required torque using the suggested bolt tightening sequence (see the bolting information section).

4 Operation

- 4.1 These valves provide tight shut-off when used under normal operating conditions in accordance with the relevant AVCO pressure/temperature charts.

Alloy Valves and Control

- 4.2 If these valves are used in a partially open (throttling) condition, the seat life may be reduced as it will be exposed to flowing media in a localized area.
- 4.3 Any media which can solidify, crystallize or polymerize should not be allowed to stand in the ball valve cavities unless regular maintenance is carried out as it could lead to damage of the seats and ball thereby dramatically reducing the life. AVCO offers cavity filled and/or steam jacketed options on this series to minimize maintenance cycles.

5 Manual Operation

- 5.1 All AVCO 1500 series ball valves are supplied with basic quarter turn lever handles as standard unless otherwise stated.
- 5.2 For valve sizes up to 2" inclusive the lever has an integral stop for fully open and fully closed positions, there is also a sliding lockable tab to prevent accidental or unauthorized opening or closing of the valve. To operate, the lockable tab should be slid upwards and the lever rotated in the required direction. The

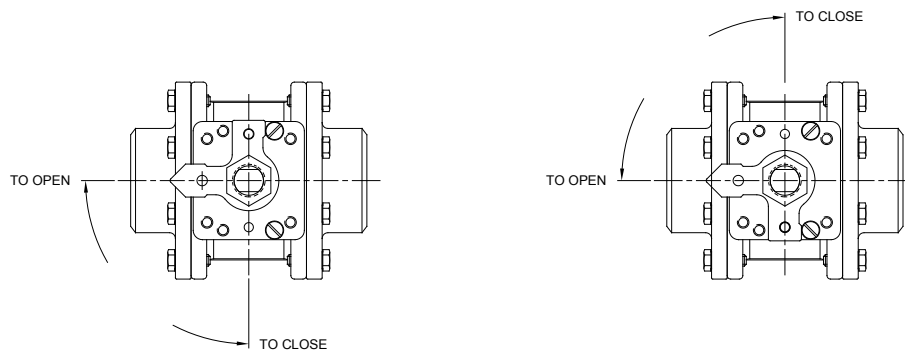

Fig. 3
Valve Handle Rotation Adjustment

tab can then be released to slide down and locate in its slot. The lever can only be correctly installed in one position. Rotating the lever clockwise closes the valve and counter-clockwise opens the valve.

- 5.3 For valve sizes 2 1/2" thru 4" there is a separate lock plate/indicator and valve lock-off is achieved by using a padlock or other suitable locking device. The handle is simply rotated provided no locking device

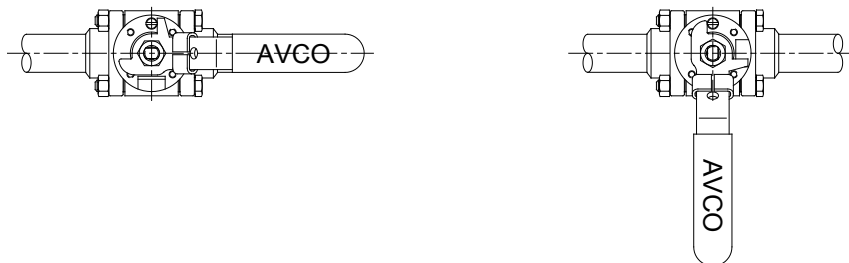

Fig. 4
Valve Open/Closed Indication

is in place. There are two stop pins per assembly which can be relocated along with the stop plate to give opposite rotation (see fig. 3) and different start positions. Thereby the valve is either clockwise to open and counter-clockwise to close or counter-clockwise to open and clockwise to close.

- 5.4 The handle or lever on all valve sizes gives visual indication as to whether the valve is in the open or closed position. If the handle/lever is in-line (parallel) with the pipeline, then the valve is open or if the handle/lever is perpendicular to (across) the pipeline, then the valve is closed.

6 Automated Operation

- 6.1 These valves can be set up for automated operation as part of a process control system. AVCO supplies a large range of pneumatic and electric actuators with associated controls to accommodate most design conditions.
- 6.2 The handle/lever, stem nut, stop pin and stop plate (2 1/2" thru 4" only) should be omitted for automated actuation if not already specified in the purchase order.
- 6.3 The stem has milled flats which are machined to exacting tolerances to ensure positive location. The

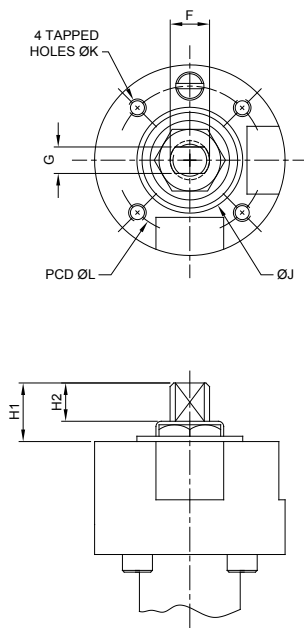

Fig. 5
Valve Stem & Mount Pad Set-Up

SIZE	F (mm)	G (mm)	H1 (mm)	H2 (mm)	J (mm)	K	L (mm)	ISO 5211
1/4" (DN 8)	0.375 (9.5)	0.224 (5.7)	0.551 (14)	0.354 (9)	0.984 (25)	M5	1.417 (36)	F03
3/8" (DN 10)	0.375 (9.5)	0.224 (5.7)	0.551 (14)	0.354 (9)	0.984 (25)	M5	1.417 (36)	F03
1/2" (DN 15)	0.375 (9.5)	0.224 (5.7)	0.551 (14)	0.354 (9)	0.984 (25)	M5	1.417 (36)	F03
3/4" (DN 20)	0.375 (9.5)	0.224 (5.7)	0.551 (14)	0.354 (9)	0.984 (25)	M5	1.417 (36)	F03
1" (DN 25)	0.438 (11.2)	0.295 (7.5)	0.669 (17)	0.472 (12)	1.181 (30)	M5	1.654 (42)	F04
1 1/4" (DN 32)	0.438 (11.2)	0.295 (7.5)	0.669 (17)	0.472 (12)	1.181 (30)	M5	1.654 (42)	F04
1 1/2" (DN 40)	0.563 (14.3)	0.339 (8.6)	1.142 (29)	0.669 (17)	1.378 (35)	M6	1.969 (50)	F05
2" (DN 50)	0.563 (14.3)	0.339 (8.6)	1.142 (29)	0.669 (17)	1.378 (35)	M6	1.969 (50)	F05
2 1/2" (DN 65)	0.787 (20)	0.551 (14)	1.693 (43)	0.709 (18)	1.575 (40)	M8	2.756 (70)	F07
3" (DN 80)	0.748 (19)	0.748 (19)	1.850 (47)	0.689 (17.5)	1.969 (50)	M10	4.016 (102)	F10
4" (DN 100)	0.748 (19)	0.748 (19)	1.850 (47)	0.689 (17.5)	1.969 (50)	M10	4.016 (102)	F10

Table 1
Valve Stem & Mount Pad Dimensions in Inches

flats also indicate valve ball position. When the flats are parallel to the pipeline, the valve is open and when the flats are perpendicular to the pipeline, the valve is closed.

- 6.4 There is no positive stop on the valve for open and closed positions when set up for actuator usage as it is intended that the actuator will control the valve travel.

Alloy Valves and Control

- 6.5 The mount pad for each valve conforms to ISO 5211 and the stem dimensions are as shown in fig. 5 and table 1 below.
- 6.6 Standard ISO brackets and couplers are available from AVCO to suit a wide range of actuator styles.
- 6.7 AVCO advises, that where an actuator is used, the valve be installed as shown in fig. 1 and as described in paragraph 1.2 for optimal use and life span.
- 6.8 It is imperative that any bracket/coupler combination allows adequate clearance to ensure that the coupler does not exert any compressive force directly on to the stem or stem nut, as this could lead to premature stem leakage and possible damage. When assembled it should be possible for the coupler to freely move up and down by a small amount.

7 Maintenance

- 7.1 AVCO valves will give a long and trouble free life provided they are operated within the specified design parameters, but occasionally maintenance is required and should be addressed as set out below:

7.2 Stem Leakage

- 7.2.1 Remove the handle/lever retaining nut or screw, handle/lever and locking tab.
- 7.2.2 Examine the disc spring washers and check the outer edges are touching and concentric. If all appears to be OK, continue to 7.2.4.
- 7.2.3 Remove stem nut, replace disc spring washers (if necessary) and ensure that the outside edges are touching concentrically. Replace the stem nut.
- 7.2.4 Tighten the stem nut until the required torque is achieved (see table 2) or until the disc springs are flattened and then back off by the minimum amount required until the lock pad can be located onto the stem nut.
- 7.2.5 Replace the handle/lever and handle/lever nut or screw.
- 7.2.6 If stem leakage still occurs the valve will require refurbishment, full instructions are listed in section 8.

7.3 Leakage at Body Joint

- 7.3.1 Check the body bolt or body screw torque settings and tighten to the required torque using the suggested bolt tightening sequence (see the bolting information section).
- 7.3.2 If leakage is still encountered the body seals will require replacement or the mating faces may be damaged and should be inspected as detailed in section 8.

7.4 In-Line Leakage

- 7.4.1 Check that the valve is fully closing and that there are no restrictions preventing the full rotation to the closed position.
- 7.4.2 If the full travel is being achieved then it is likely that the valve seats or ball is damaged or worn or the ball is incorrectly fitted (see section 10) and may require replacement or correction. See section 8 for details on how to carry out a complete refurbishment.

7.5 Leakage at Pipeline Joint

- 7.5.1 For screwed valves ensure that the joint has been correctly tightened and adequate jointing material used.

Alloy Valves and Control

- 7.5.2 For flanged valves ensure that mating faces and gasket are not damaged and verify that all bolts have been tightened to the relevant torque giving adequate gasket compression. Gasket compression and bolting torque for flanged joints should be specified by the gasket supplier.
- 7.5.3 For weld end valves ensure that the weld has no leak points or 'burn through' and repair as required using the instructions detailed in section 3 as appropriate.

7.6 Leakage at Bonnet Joint

- 7.6.1 A seal is present at the joint between the main body and cryogenic bonnet.
- 7.6.2 If leakage occurs the bonnet screws should be checked and tightened to the required torque as shown in table 2.
- 7.6.3 If leakage still occurs it will be necessary to replace the bonnet seal as described below:

NOTE: Leakage at the bonnet seal is also an indication that the secondary stem seal is leaking, however the valve will still operate normally as the secondary stem seal is not critical and does not need correcting unless bad mechanical wear is present, thereby necessitating a full refurbishment. If the bonnet is removed, then the stem seal can be tightened as described in para 7.2.

WARNING: Ball valves are designed as pressure containing equipment and as such a risk assessment should be carried out to ensure that no pressurized fluid or gas is contained in the ball cavity and relevant procedures followed for the handling of hazardous materials before any work commences.

- 7.6.4 Operate the valve to either fully open or fully closed position.
- 7.6.5 Slowly loosen and remove the four bonnet bolts.
- 7.6.6 Carefully remove the bonnet assembly upwards whilst maintaining the fully open or closed position.
- 7.6.7 The valve stem will now be exposed and can be tightened/inspected as per para 7.2.
- 7.6.8 Discard the bonnet seal and inspect the mating surfaces for any imperfections. Thoroughly clean both surfaces with a suitable cleaning fluid. If there is any build-up of solids, use a blunt tool (preferably not metal) and ensure the mating surfaces are not scratched. If any mating surface shows signs of eroded or corroded leak paths or damage to machined areas, it should be replaced.
- 7.6.9 Fit a new bonnet seal and carefully lower the bonnet back onto the valve body whilst taking care that the valve stem and bonnet stem locate correctly.
- 7.6.10 Insert the bonnet bolts and tighten to the required torque using the suggested bolt tightening sequence (see the bolting information section).
- 7.6.11 Operate the valve several times, re-check the bonnet bolt torques and tighten if required.

8 Refurbishing

- 8.1 AVCO Valves can be refurbished if the need arises and complete maintenance kits are available or individual components purchased as required. A maintenance kit consists of thrust washer, packing washers, disc spring washers, seats and body seals in quantities relevant to the specified valve size.

NOTE: If any of the seal, seat or washer materials differ to that of the originally supplied specification, then the nameplate must be revised or the valve tagged to indicate the change as the temperature and pressure range could be affected.

WARNING: Ball valves are designed as pressure containing equipment and as such a risk assessment should be carried out to ensure that no pressurized fluid or gas is contained in the ball cavity and relevant procedures followed for the handling of hazardous materials before any work commences.

NOTE: The following instructions assume that all relevant safety checks have been carried out and are purely aimed at valve refurbishment.

8.2 Prepare a clean working area.

8.3 If fitted, remove any actuators and associated brackets per manufacturers' instructions.

8.4 With the valve in the open position, remove the body bolts or screws.

8.5 Gently slide the center body section from between the end caps whilst prizing the end caps apart to clear the location ring. Take care not to damage the mating faces. The seat retainers may come loose and should be restrained to prevent them from falling and becoming damaged.

8.6 Remove the body seals and seat retainers complete with seats.

NOTE: The seat retainers are integral to the end cap for valve sizes 3/4" and below.

8.7 Whilst supporting the ball to prevent it dropping out and potentially damaging the ball surface, rotate the valve to the closed position and remove the ball.

8.8 Inspect the bonnet assembly and if it is considered to be in good condition skip to paragraph 8.29.

8.9 Unscrew the bonnet bolts and carefully lift the bonnet assembly off the main body.

NOTE: Paragraphs 8.10 thru 8.18 are relevant to the bonnet stem and paragraphs 8.19 thru 8.25 are relevant to the body stem. Either of these sections can be skipped if the stem assemblies are determined to be in good condition

8.10 If fitted, unscrew the handle retaining nut/screw and remove the handle/lever. The stop pins can also be removed if desired.

8.11 Remove the bonnet stem nut locking tab.

8.12 Use a wrench on the bonnet stem flats to prevent the stem from turning, unscrew the stem nut and remove. The disc spring washers, gland ring and packing can now be removed. The stem and thrust washer can be withdrawn from the bonnet.

8.13 Thoroughly clean all components with a suitable cleaning fluid. If there is any build-up of solids, use a blunt tool (preferably not metal) and ensure machined surfaces are not scratched. If any component shows signs of eroded or corroded leak paths or damage to machined areas, it should be replaced.

8.14 Fit the thrust washer onto the stem.

8.15 Insert the stem with thrust washer up into the bonnet.

8.16 Ease the packing washers onto the stem whilst taking care not to damage them, followed by the gland ring and stop plate (2 1/2" thru 4"). Place the disc spring washers onto the stem whilst ensuring that the outside edges are touching concentrically. Replace the stem nut and Tighten the stem nut until the required torque is achieved (see table 2) or until the disc springs are flattened and then back off by the minimum amount required until the lock pad can be located onto the stem nut.

8.17 Operate the stem several times and re-tighten if required.

8.18 Screw in the stop pin(s), replace the handle/lever and handle/lever nut or screw.

Alloy Valves and Control

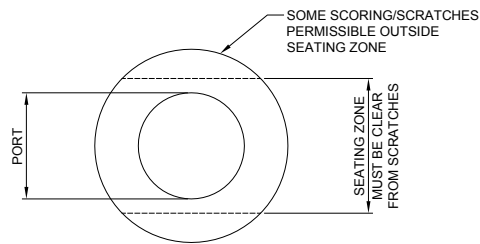

Fig. 6
Ball Inspection

- 8.19 Remove the stem nut locking tab.
- 8.20 Use a wrench on the stem flats to prevent the stem from turning, unscrew the stem nut and remove. The disc spring washers, gland ring and packing can now be removed. The stem and thrust washer can be withdrawn via the body cavity.
- 8.21 Thoroughly clean all components with a suitable cleaning fluid. If there is any build-up of solids, use a blunt tool (preferably not metal) and ensure machined surfaces are not scratched. If any component shows signs of eroded or corroded leak paths or damage to machined areas, it should be replaced.
- 8.22 Fit the thrust washer onto the stem.

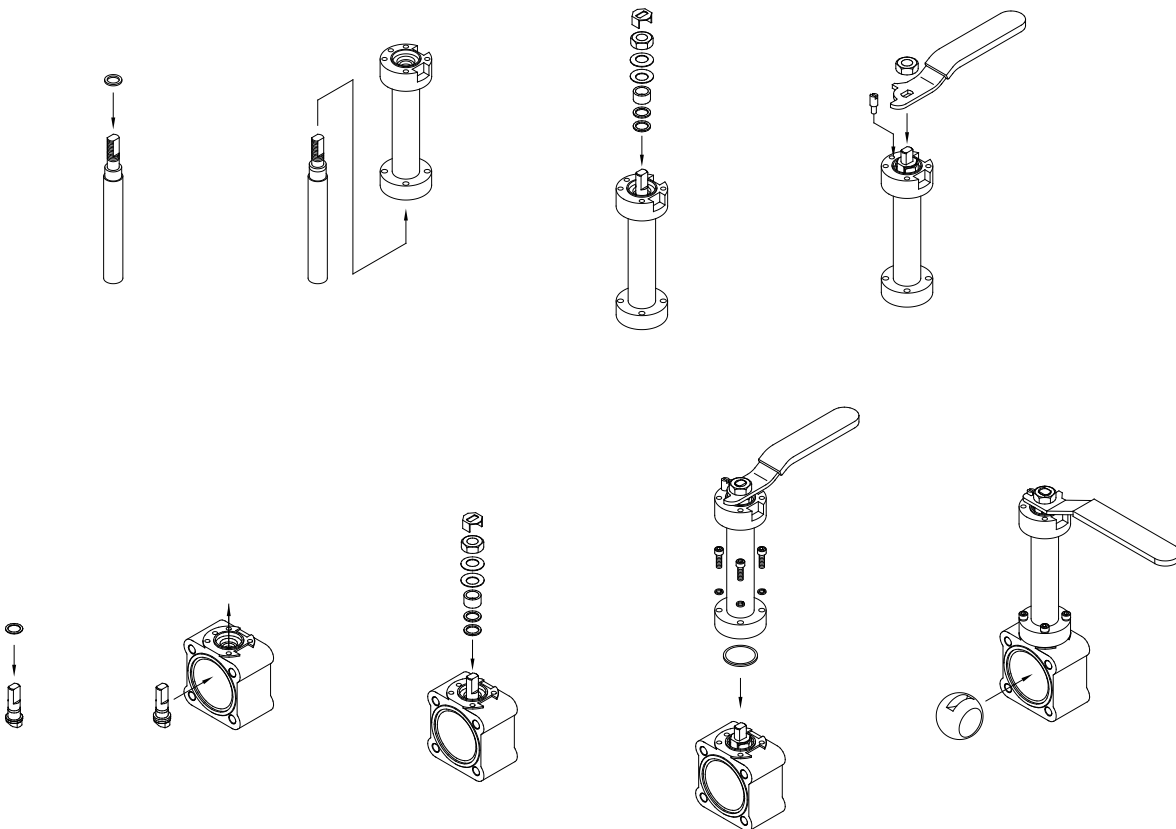

Fig. 7
Valve Re-Assembly Procedure

Alloy Valves and Control

- 8.23 Insert the stem with thrust washer up into the valve body.
- 8.24 Ease the packing washers onto the stem whilst taking care not to damage them, followed by the gland ring and stop plate (2 1/2" thru 4"). Place the disc spring washers onto the stem whilst ensuring that the outside edges are touching concentrically. Replace the stem nut and Tighten the stem nut until the required torque is achieved (see table 2) or until the disc springs are flattened and then back off by the minimum amount required until the lock pad can be located onto the stem nut.
- 8.25 Operate the stem several times and re-tighten if required.
- 8.26 Fit a new bonnet seal and carefully lower the bonnet back onto the valve body whilst taking care that the valve stem and bonnet stem locate correctly.
- 8.27 Insert the bonnet bolts and tighten to the required torque using the suggested bolt tightening sequence (see the bolting information section).
- 8.28 Operate the valve several times, re-check the bonnet bolt torques and tighten if required.
- 8.29 The ball must have no scratches or scoring, other than minor signs of rubbing, around its seating periphery (fig. 6). Any components that do not pass inspection should be replaced.
- 8.30 Replace the ball into the valve body (whilst in closed position and considering section 10 for vent location) and carefully rotate to the open position. Insert the seats, retainer rings and body seals.

NOTE: A trace of silicon based lubricant or clean grease (i.e. Petroleum jelly), if compatible with pipeline media, will assist with rebuilding by holding the seats, retainers and body seals in place. **DO NOT** use grease with abrasive additives.

- 8.31 Ease the completed body assembly (as shown in fig. 2 for sizes up to 2" inclusive) between the end caps ensuring that the faces and body seals are not trapped or damaged.
- 8.32 Insert body bolts or screws and tighten to the required torque using the suggested bolt tightening sequence (see the bolting information section). It is suggested that periodic opening and closing be performed during the tightening sequence to help with concentricity, as it is possible for the ball to be trapped between the seats, especially in horizontal applications.
- 8.33 All of the above procedures can be carried out without the need to disturb flanged or threaded end cap connections to the pipeline, as the center section is designed to be removed alone to cater for welded connections. It is at the owner/operators discretion as to whether these connections be renewed.

9 Bolting Information

- 9.1 The stem nut should be tightened finger tight and then torqued per table 2 or tightened with a wrench until the disc spring washers are fully flat. Once the required tightening has been achieved, the nut should be backed off no more than 1/8 turn until the lock pad can be assembled onto the stem.
- 9.2 The body bolts should be tightened until finger tight and then gradually fully tightened per the bolting sequence shown in figs. 8 or 9 to the torque shown in table 2. It is important that tightening be done gradually so as not to trap or pinch any part of the seats or seals and to maintain concentricity.
- 9.3 The bonnet bolts should be tightened until finger tight and then gradually fully tightened per the bolting sequence shown in fig. 8 to the torque shown in table 2. It is important that tightening be done gradually so as to ensure the bonnet stem locates evenly onto the body stem.

Alloy Valves and Control

9.4 Four bolt sequence.

- 9.4.1 First round to 30% torque - 1-2, 3-4
- 9.4.2 Second round to 60% torque - 1-2, 3-4
- 9.4.3 Third round to 100% torque - 1-2, 3-4
- 9.4.4 Final checking round - 1,3,2,4

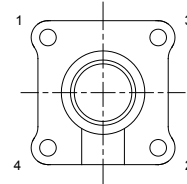

Fig. 8

9.5 Eight bolt sequence

- 9.5.1 First round to 30% torque - 1-2, 3-4, 5-6, 7-8
- 9.5.2 Second round to 60% torque - 1-2, 3-4, 5-6, 7-8
- 9.5.3 Third round to 100% torque - 1-2, 3-4, 5-6, 7-8
- 9.5.4 Final checking round - 1,5, 3, 7, 2, 6, 4, 8

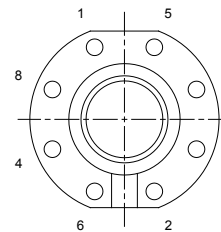

Fig. 9

- 9.6 If a bolt, screw or nut is damaged or lost, it should be replaced with one of exactly the same specification as that originally supplied. AVCO holds spares in stock.

10 Determining Correct Installation of Vented Ball

- 10.1 The 1500 series ball valve has a vented ball to prevent pressure build-up in the ball cavity and as such it is important the ball be correctly installed.
- 10.2 Each valve supplied will have one end cap marked 'HP' for high pressure end.

Valve Size	Bonnet Bolts		Body Bolts		Stem Nuts	
	Size	Torque (in.lbs)	Size	Torque (in.lbs)	Size	Torque (in.lbs)
1/4"	M5	40	M6	70	3/8-24 UNF	29
3/8"	M5	40	M6	70	3/8-24 UNF	29
1/2"	M5	40	M6	70	3/8-24 UNF	29
3/4"	M5	40	M6	70	3/8-24 UNF	29
1"	M5	40	M8	170	7/16-20 UNF	29
1 1/4"	M5	40	M10	340	7/16-20 UNF	29
1 1/2"	M6	70	M10	340	9/16-18 UNF	63
2"	M6	70	M12	590	9/16-18 UNF	63
2 1/2"	M8	170	M10	340	M20	210
3"	M10	340	M10	340	1-14 UNF	482
4"	M10	340	M12	590	1-14 UNF	482

Table 2
Valve Torque Settings

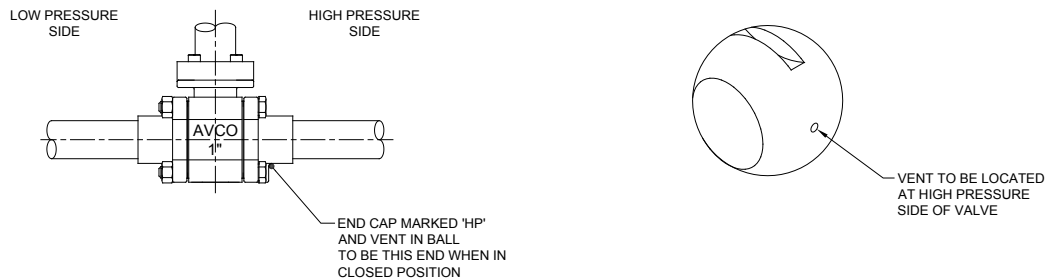

Fig. 10
Vented Ball Installation

- 10.3 The user shall determine which end of the valve will be the higher pressure when the valve is in the 'closed' position. This may or may not coincide with the flow direction and is specific to the type of system.
- 10.4 The end cap marked 'HP' must be installed at the high pressure side as determined in paragraph 10.3.
- 10.5 The vent in the ball must always be at the same end as the end cap marked 'HP' for correct operation. Failure to do so will result in operational leakage.

11 Valve Conformance

- 11.1 The valve shall be deemed to conform with its originally supplied specifications provided that:
- 11.1.1 The maintenance kit material is identical to that of the originally specified valve or the name-plate be revised to show the new conditions.
 - 11.1.2 Any component that is replaced during maintenance or repair is an AVCO authorized spare part and is specific to the originally specified valve. Any component of the valve can be replaced, but AVCO recommends that if the body becomes damaged then the complete valve be replaced.
 - 11.1.3 Parts from different AVCO valve series should not be inter-changed unless authorized by AVCO.
 - 11.1.4 Parts from other valve manufacturers must not be used.
 - 11.1.5 If the valve is altered in any way from that of the original specification or without consent from AVCO, then no liability can be accepted by AVCO (Alloy Valves & Control).

12 Safety Precautions

- 12.1 Ascertain what media the pipeline carries before removing or working on any fitted valve. The media can be corrosive, toxic, flammable or a contaminant. Where there is evidence of harmful or hazardous media ever flowing through the valve, then utmost care must be taken. As a minimum AVCO suggests the following precautions be taken, but it is the responsibility of the owner/operator to ensure that a risk assessment is carried out and relevant safety procedures followed thereof.
- 12.2 Wear eye protectors.
- 12.3 Wear protective overalls and gloves.

Alloy Valves and Control

- 12.4 Wear protective headgear.
- 12.5 Wear protective footwear.
- 12.6 Ensure running water is easily accessible.
- 12.7 Have a suitable fire extinguisher nearby.
- 12.8 Check Upstream and downstream pressure gauges to ensure the pipeline contains no pressure.
- 12.9 Ensure any pressurized media in the ball or cavity is released by opening the valve half open.
- 12.10 Ideally the valve should be flushed or decontaminated with the valve in the half open position to clear ball and body cavity.

13 Exploded Views

- 13.1 Figures 1 & 12 and table 3 show the typical exploded views and part descriptions for all valve sizes, but please consider that the end caps (item 2) may differ to those actually shown in these figures.
- 13.2 For sizes 1/4" thru 3/4" the retainer (item 3) is integral with the end cap (item 2).

Item	Description	Item	Description
1	Body	15	Body Nut
2	End Cap	16	Stop Pin
3	Retainer*	17	Handle
4	Ball	18	Handle Sleeve
5	Stem	19	Wrench Block
6	Ball Seat	20	Handle Bolt
7	Body Seal	21	Lock Pad
8	Thrust Washer	22	Bonnet Extension
9	Packing	23	Stem Extension
10	Gland Ring	24	Bonnet Gasket
11	Disc Spring	25	Bonnet Bolt
12	Lock Tab	26	Bonnet Washer
13	Stem Nut	27	Disc-Lock Washer
14	Body Bolt		

* This item is integral with the end cap (item 2) on sizes 1/4" thru 3/4"

Table 3

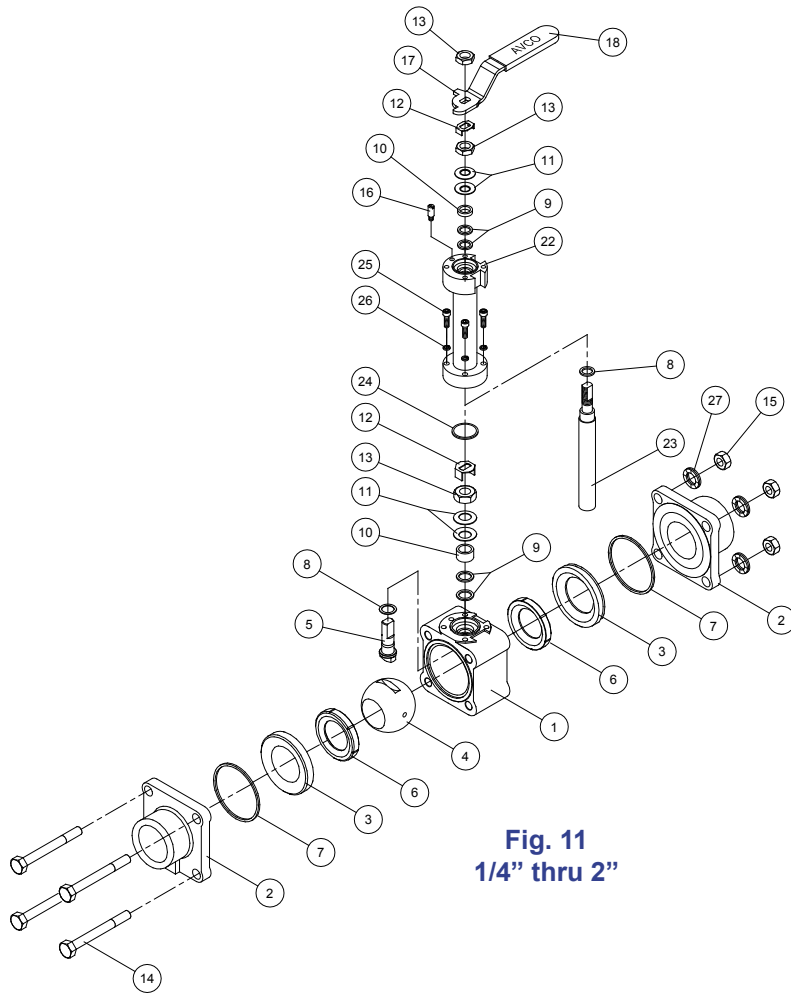

Fig. 11
1/4" thru 2"

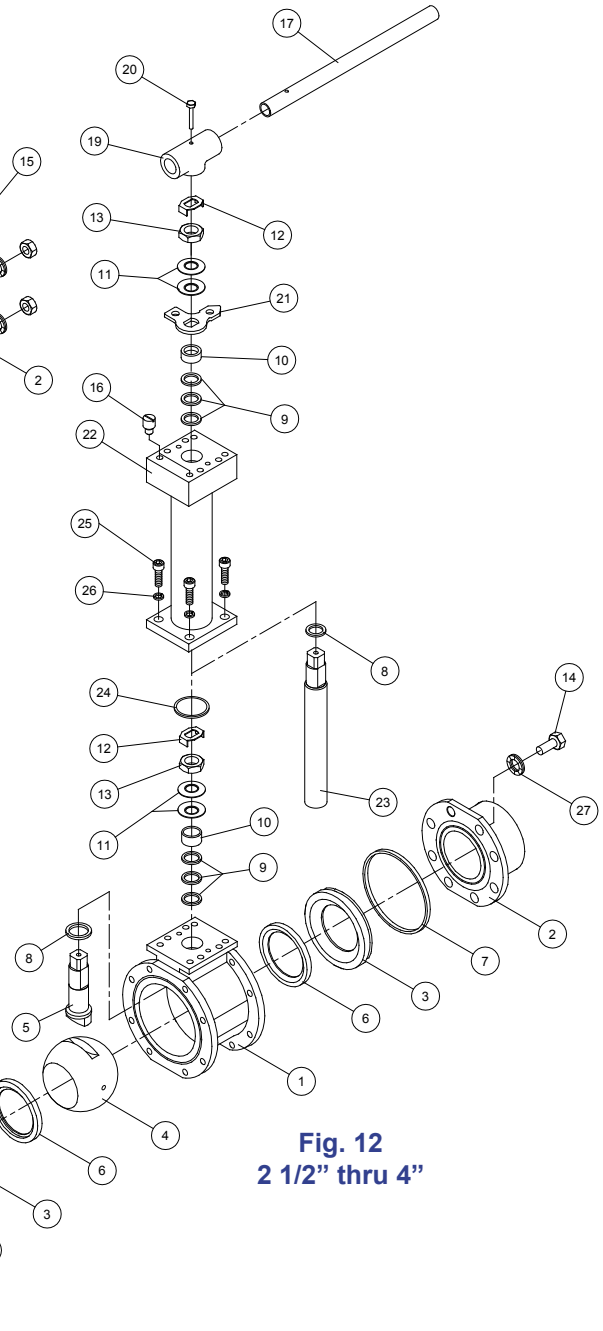

Fig. 12
2 1/2" thru 4"