

Alloy Valves and Control

Actuator Specifications	P1A, P1A-XOV			
Torque lb/Nm	445"lbs / 50Nm			
Supply Voltage	12vac/dc	24vac/dc	120vac	230vac
Max Inrush Current	5.1A	5.4A	1.5A	1.0A
Running Current	1.7A	1.8A	0.5A	0.3A
Runtime (90°@60/50Hz)	20 sec			
Weight	8lbs / 3.6kg (6.6lbs / 3.0kg XOV)			
Mechanical Connections	ISO5211 F07 8pt 17mm			
Electrical Entry	(2) 1/2" NPT			
Electrical Terminations	14 - 18 Ga.			
Environmental Rating	4, 4X			
Manual Override	5mm Socket Drive (P1A only)			
Control	On/Off-Jog, Proportional			
Case material	Aluminum Alloy, Powder Coated			
Motor Protection (On/Off)	Split Phase Capacitor			
120/230 vac Operation	275°F/135°C Thermal H Class			
Motor Protection (On/Off)	DC Brush Type			
12/24 VDC	275°F/135°C Thermal H Class			
Ambient Temperature	-22°F to +150°F			
Operating Range	-30°C to +65°C			



An electric actuator designed for load requirements of up to 445"lbs. The actuator comes standard with two auxiliary switches (shared common, rated at 3A 250V Max), an internal low power heater, a NEMA 4X environmental rating, and in 12VAC/DC, 24VAC/DC, 120VAC or 230VAC supply voltages. The P1A mechanical connections are ISO5211 compliant, utilizing an F07 bolt pattern and an 8 point 17mm female drive. The P1A Series can be ordered as an on/off or two position model that can also be used in bump/jog applications. Or it can be ordered with an internal proportional control card that accepts a wide range of control signals and generates multiple feedback signals. This series is available in two different models: The P1A has built-in manual override capabilities utilizing a 5mm side-mounted hex key socket, while the P1A-XOV has no provisions for manual override capabilities.

P1A - 120 P N 4 - XOV

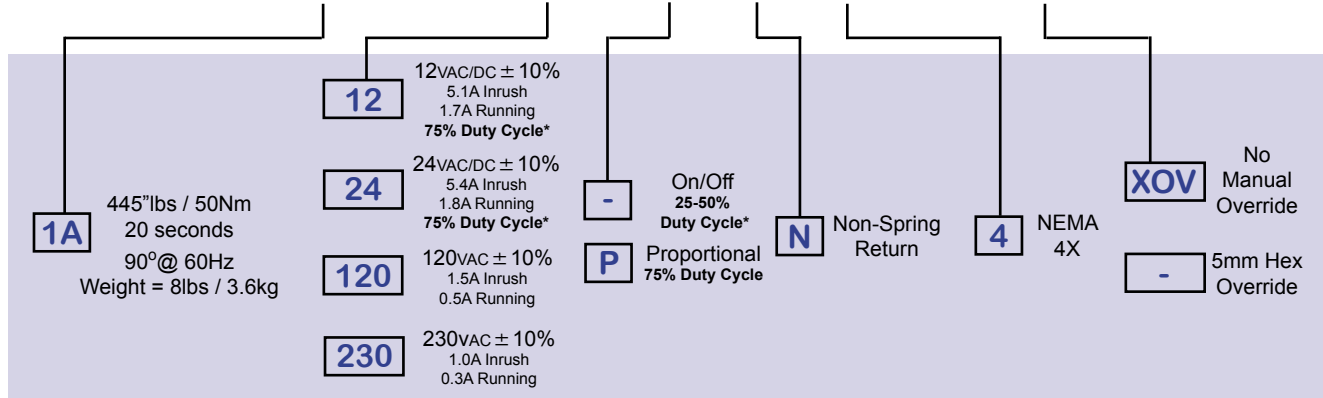

ISO F07 Mounting Detail, 5mm socket override and 8 point 17mm female drive on P1A Series actuators.

* Duty cycle is defined as the ratio of run time vs. off time, and is a function of environmental conditions including ambient temperature, supply voltage and control signal stability. Note: Duty Cycle rating on ALL proportional control and all 12/24VAC/DC actuators is 75%. All others are 25-50% depending on the application.



Simplified wiring under the cover makes field connections easier and less prone to loose connections and wiring errors.

Alloy Valves and Control

Application Notes:

1. These actuators are designed to be used in either a horizontal or upright position.
Do NOT mount the actuator with the top below a horizontal position.
2. When installing conduit, use proper techniques for entry into the actuator. Use drip loops to prevent conduit condensate from entering the actuator.
3. Both NPT conduit ports MUST use proper equipment to protect the NEMA 4x integrity of the housing.
4. The internal heater is to be used in ALL applications.
5. Do NOT install the actuator outdoors or in humid environments unless it is powered up and the heater is functioning.
6. Use proper wire size to prevent actuator failure (see chart below for proper wire sizing).

P1A Series Dimensional Data

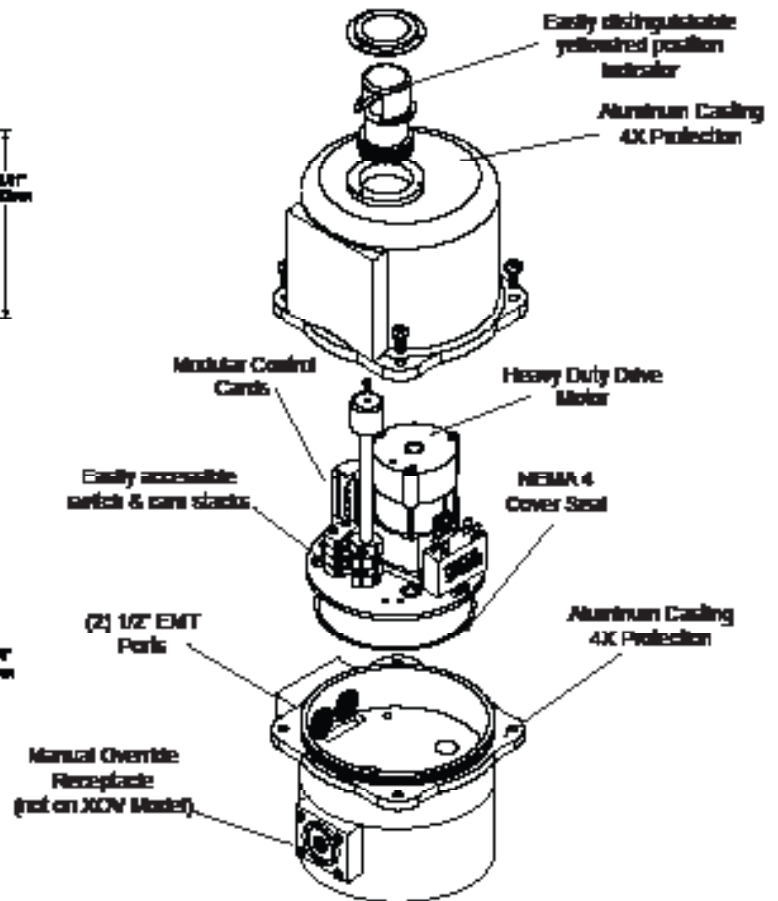
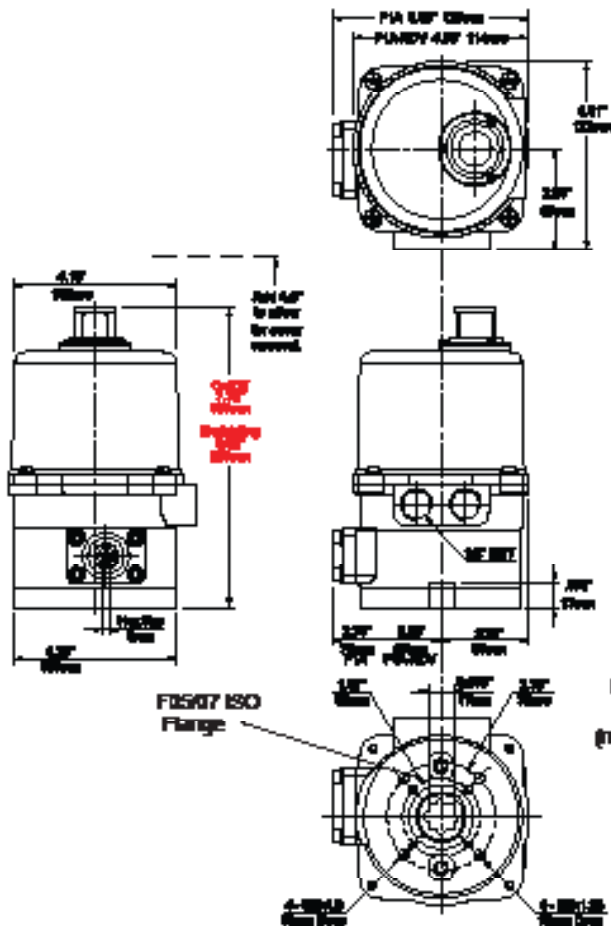

P1A Series Exploded View

Alloy Valves and Control

Wire sizing data is provided in the table below to assist in the selection of the proper wire size for AVCO P1A series actuators using various wire sizes over distance. Please make sure to reference the correct voltage and do not exceed the indicated length of the wire run for each model.

Wire Sizing Data

MAX distance between Actuator and Supply (feet)				
Wire Gage	P1A-12 3.0A	P1A-24 0.8A	P1A-120 1.5A	P1A-230 1.0A
18	28	207	551	1584
16	43	328	866	2489
14	70	524	1399	4021
12	107	802	2139	6150

Switch sequencing data is provided in the table below to show the change-of-state points during the rotation of the actuator from OPEN to CLOSED and back again. Switches for terminals 3 thru 6 are set at the factory and should NOT be changed. The INCLUDED auxiliary switches SW3 & SW4 are for terminals A thru F and those setpoints may be modified if need be.

Switch Logic Map and Switch/Cam Arrangement

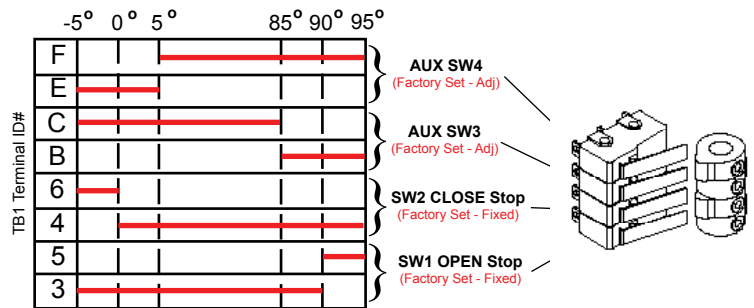

Wiring Diagrams for P1A Series

Proportional Control

Control Signal Inputs (selectable and programmable):
2-10vdc, 1-5vdc, 4-20mA

Common cannot be ground referenced. Signal return MUST be isolated from ground.

Input impedance: 100k ohms (2-10vdc)
200k ohms (1-5vdc)
250 ohms (4-20mA)

Sensitivity: 100mV (2-10vdc)
50mV (1-5vdc)
80uA (4-20mA)

Feedback Signal Output (selectable):
2-10vdc or 4-20mA
Referenced to Signal Return terminals.
Max Load: 500 ohms

There are no alarm on fail functions on this controller.

Terminals accept 14-18ga solid/stranded wire.

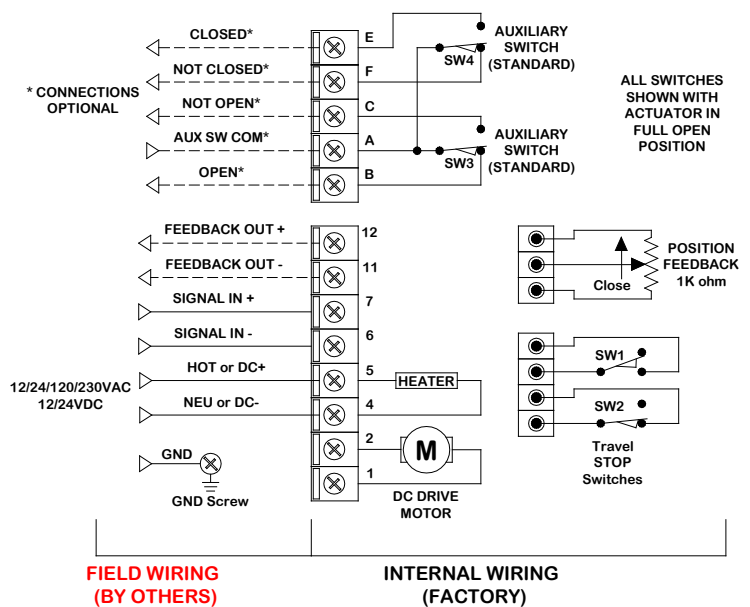

Wiring Diagrams for P1A Series (continued)

On/Off/Jog Control

Field Control Device may be relay contact, Switch or Triac type. Pilot device 3A MAX. Auxiliary switches are rated 3A @ 250vac MAX. Terminals A-F are dry type Form C. Terminals accept 14-18ga solid/stranded wire.

Parallel control of multiple On/Off actuators requires isolation relays. (Refer to Technical Wiring Supplement)

